

# A12V Variable Displacement Piston Pump

**New Development Variable Displacement Piston Pumps**, High Pressure Pumps, 380/420 BAR Working Pressure. High Rotational Speed, High Efficiency, Slim Design, Cast Iron Pump Body, Re-Designed in 2025.

## Designation;

40cc, 60cc, 75cc, 92cc, 120cc, 130cc, 150cc

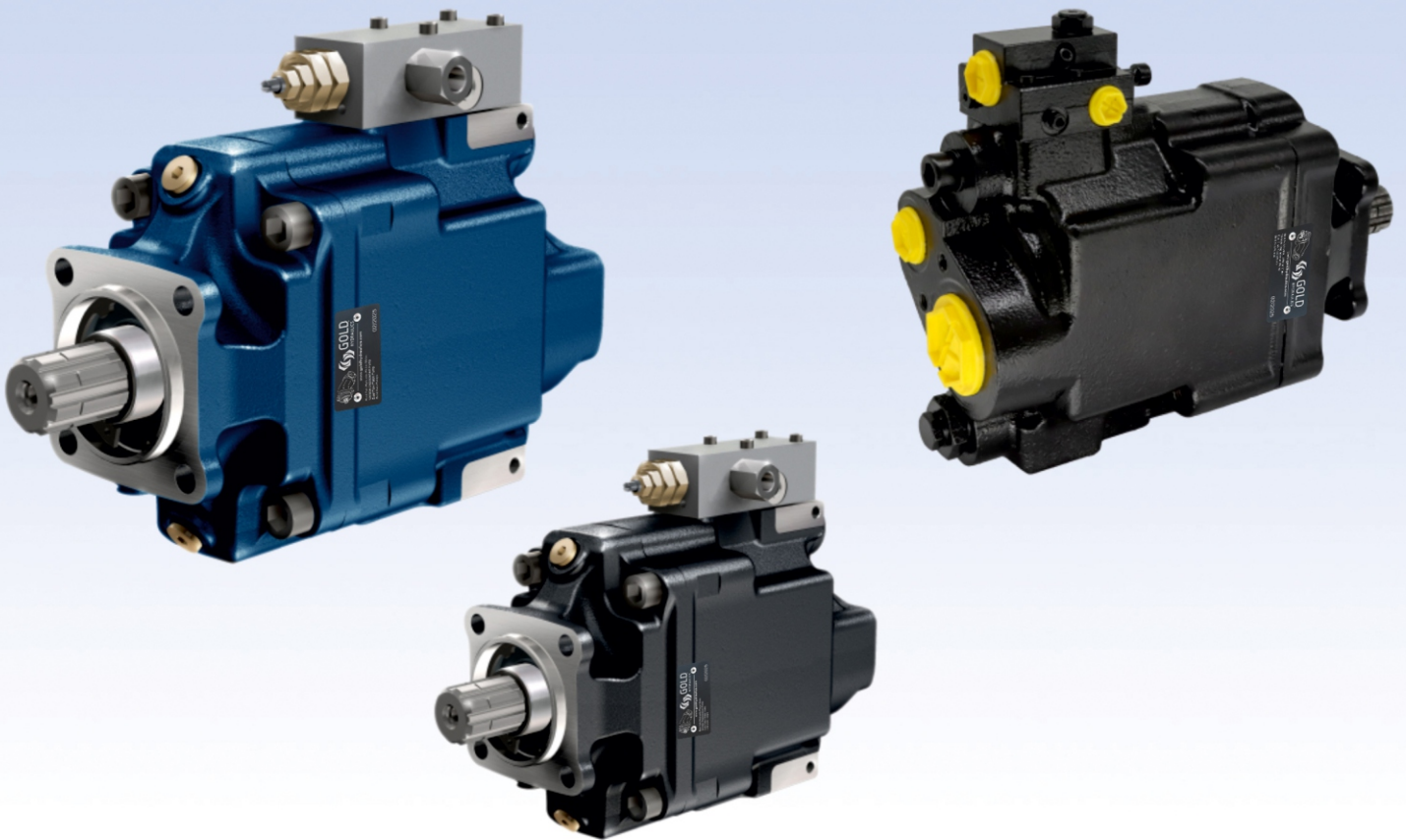

[www.goldhydraulics.com](http://www.goldhydraulics.com)

## Characteristics of the A12V Variable Dsplcmnt Piston Pumps

Pump MODEL	DISPL. (cc)	MAX. OPERATING PRESSURE (bar)	MAX. PEAK PRESSURE INTERMITTNT (bar)	TORQUE AT 300 BAR (N.m)	MAX.SPEED AT FULL DISPLACMNT (rpm)	MAX. SPEED IN STAND BY (rpm)	WEIGHT (kg)	OVERHANG TORQUE (N.m)
<b>A12V 40</b> (CW/CCW) <i>new bi-directional</i>	40	400	420	225	3000	3000	26	34
<b>A12V 60</b> (CW/CCW) <i>new bi-directional</i>	60	400	420	335	2600	3000	26	34
<b>A12V 75</b> (CW/CCW) <i>new bi-directional</i>	75	400	420	420	2000	3000	26	34
<b>A12V 92</b> (CW/CCW) <i>new bi-directional</i>	92	400	420	515	1900	3000	26	34
<b>A12V 120</b> (CW/CCW) <i>new bi-directional</i>	120	380	400	675	2100	3000	26	34
<b>A12V 130</b> (CW/CCW) <i>new bi-directional</i>	130	380	400	730	2100	3000	28	38
<b>A12V 150</b> (CW/CCW) <i>new bi-directional</i>	150	380	400	840	2000	3000	28	38

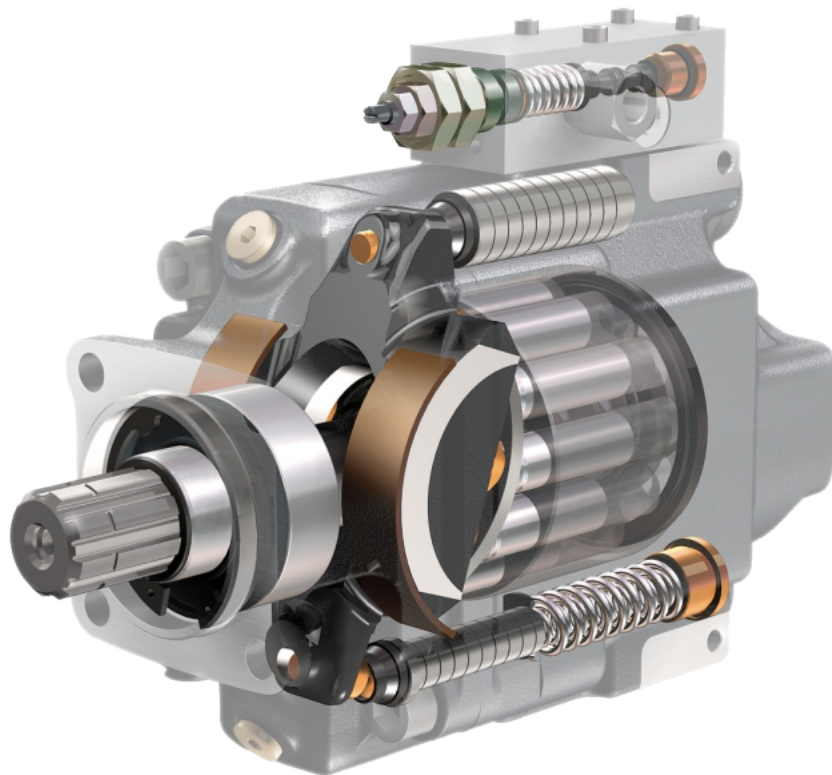

## Ordering Code; A12V Variable Dsplcmnt Piston Pumps

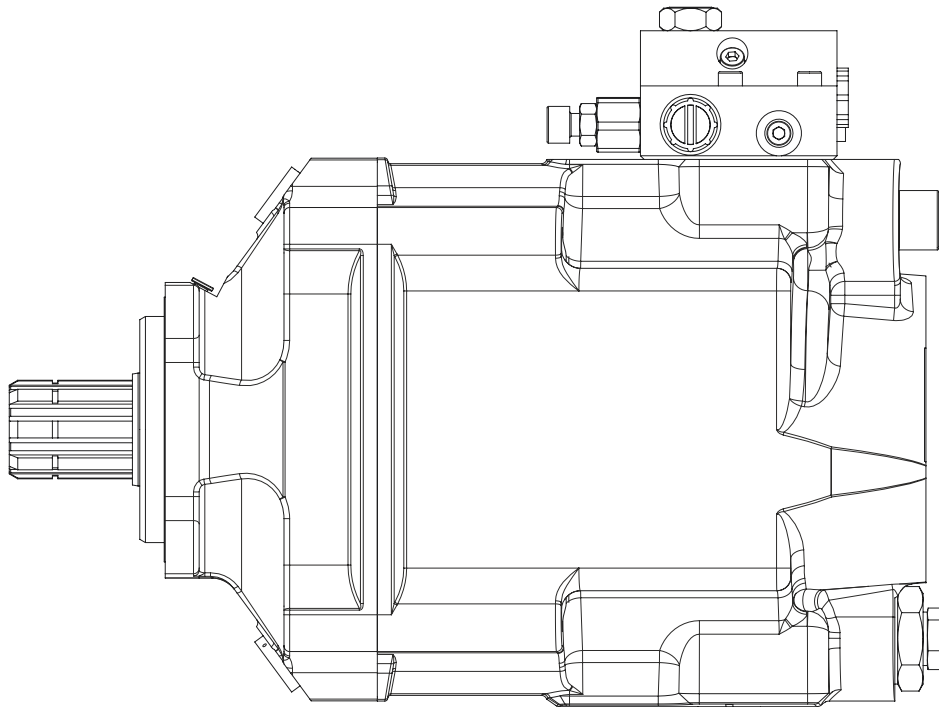
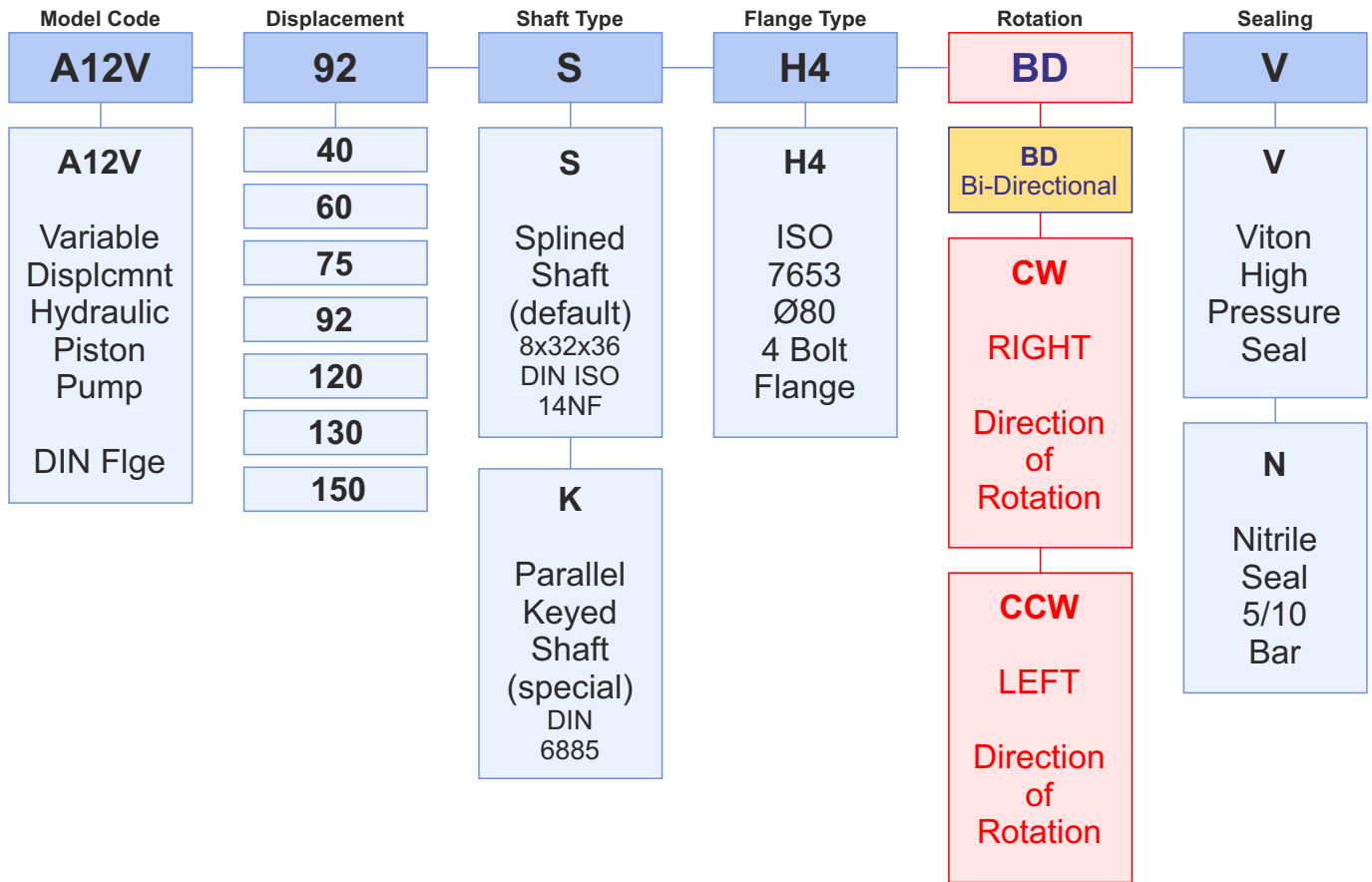

# A12V - all size Bi-Directional Version

40cc, 60cc, 75cc, 92cc, 110cc, 120cc, 130cc, 150cc

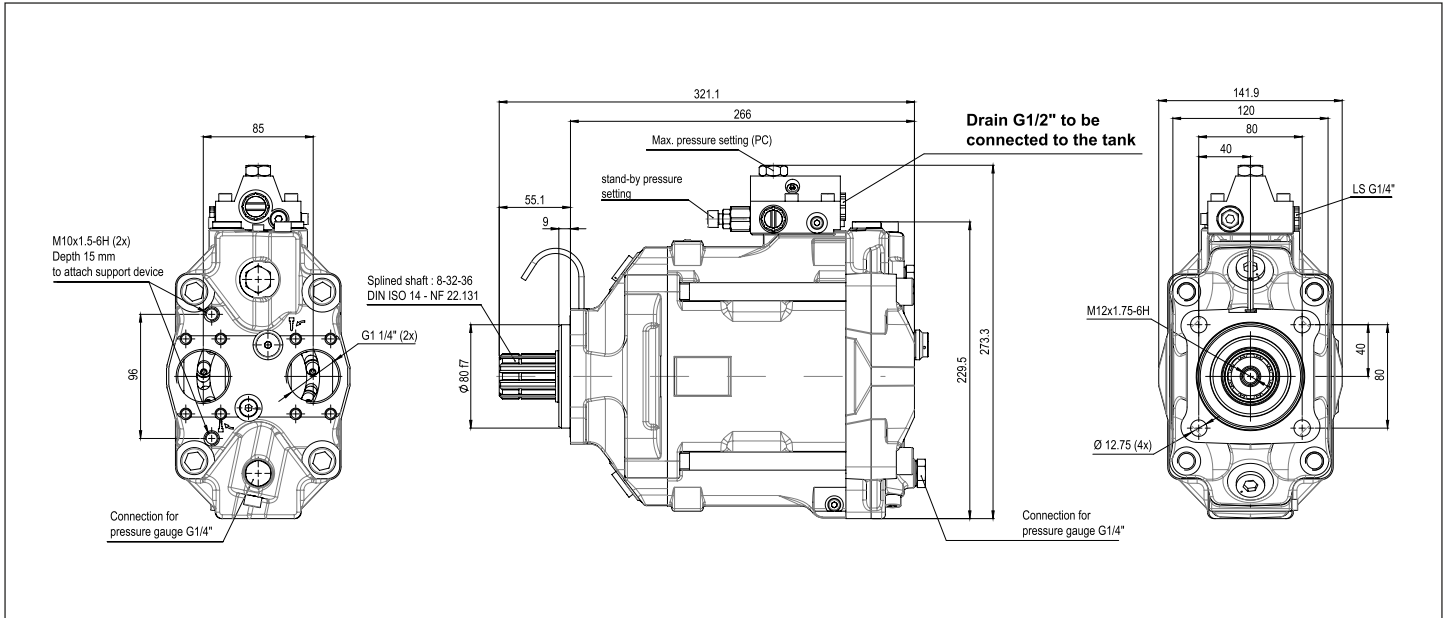

## Bi-Directional Rotation

Clockwise (CW)

Counter-clockwise (CCW)

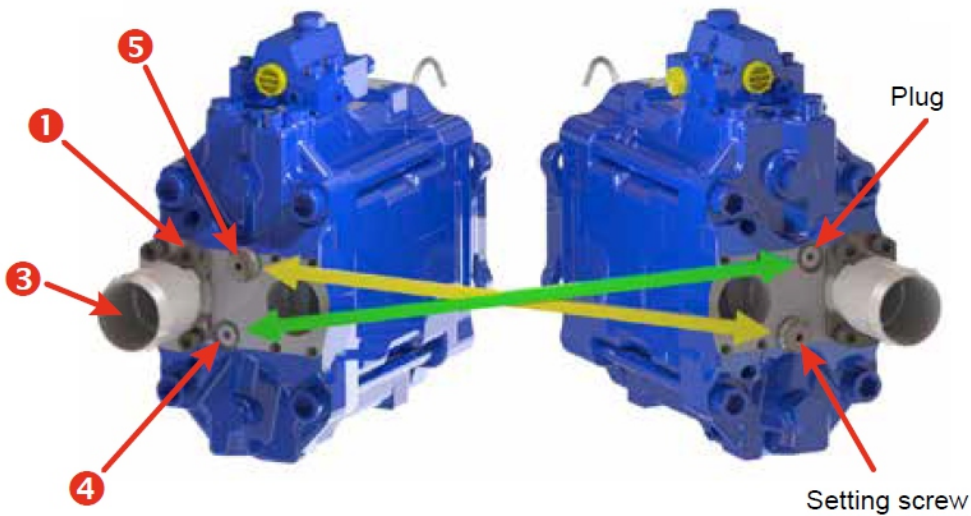

# A12V - 40 cc Variable Piston Pump

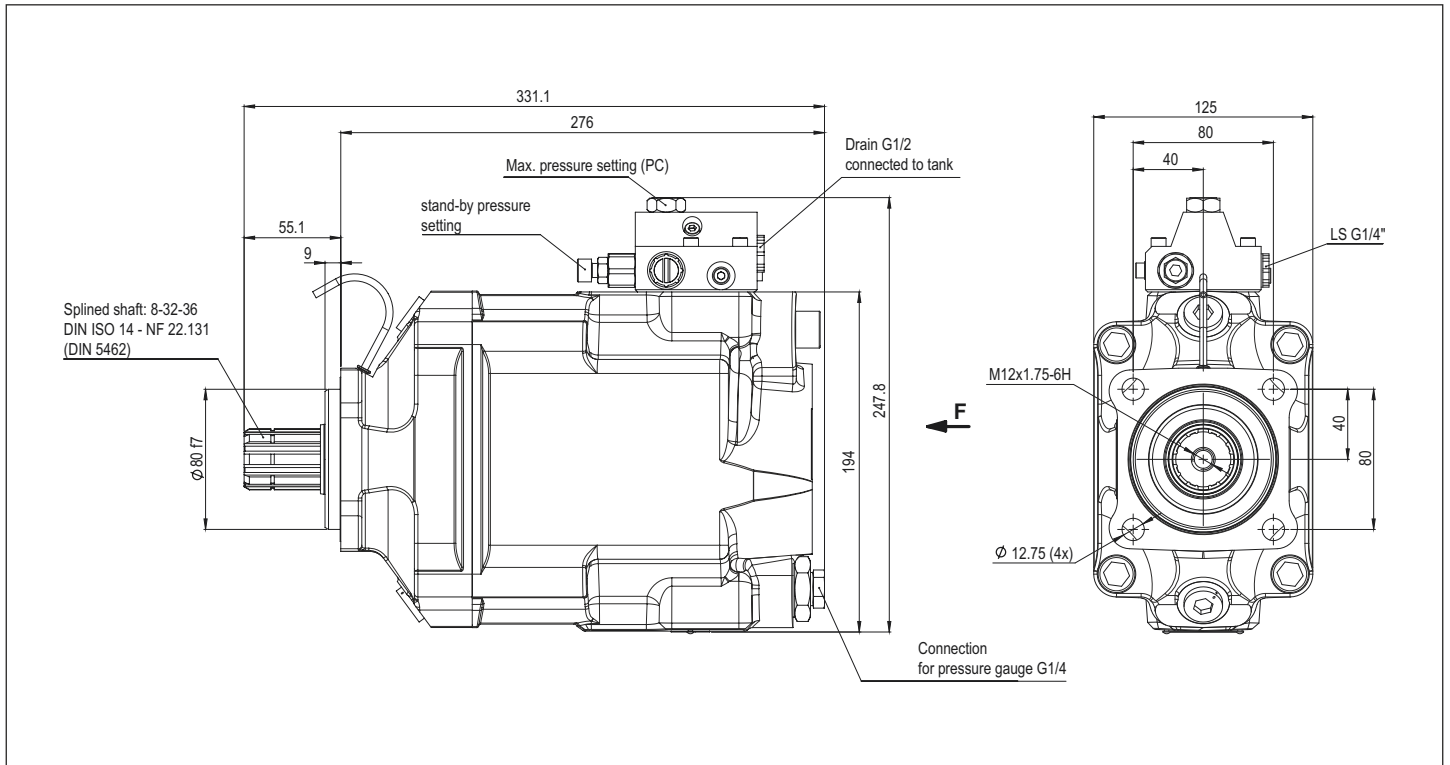

**View from F**

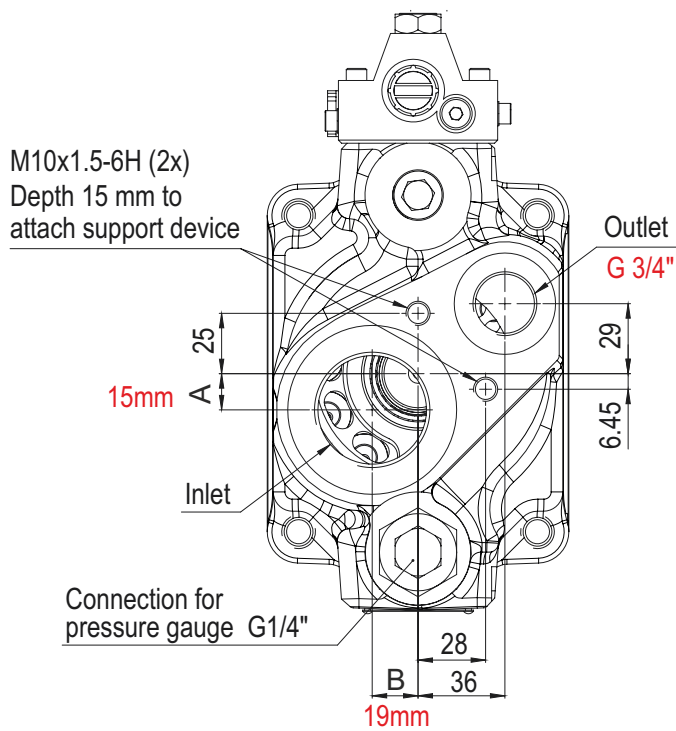

**CW**

**View from F**

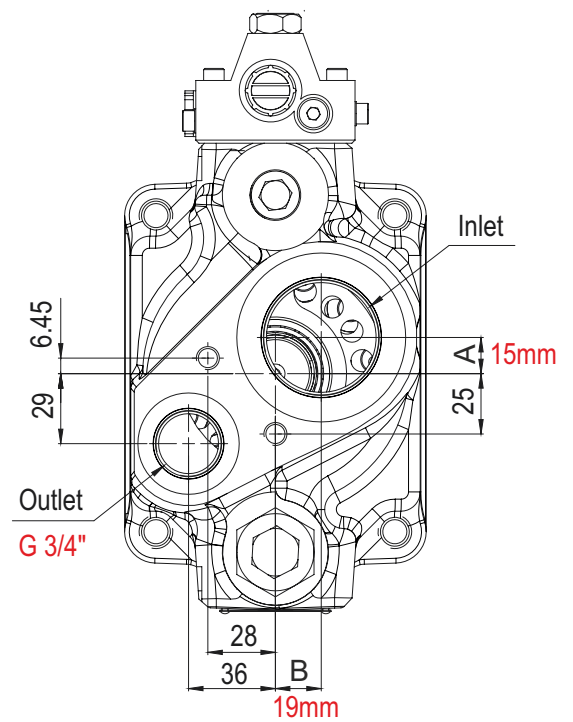

**CCW**



# A12V - 60 cc Variable Piston Pump

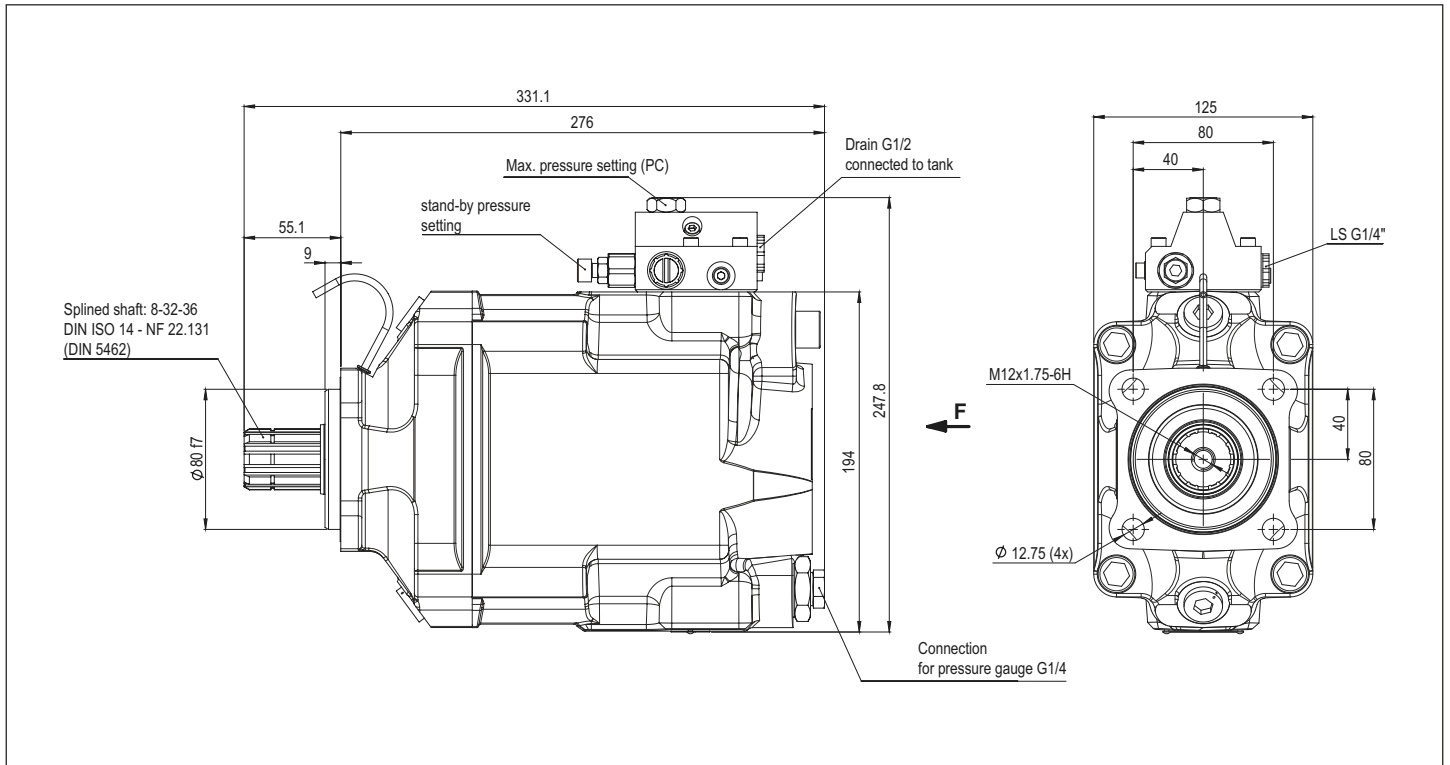

**View from F**

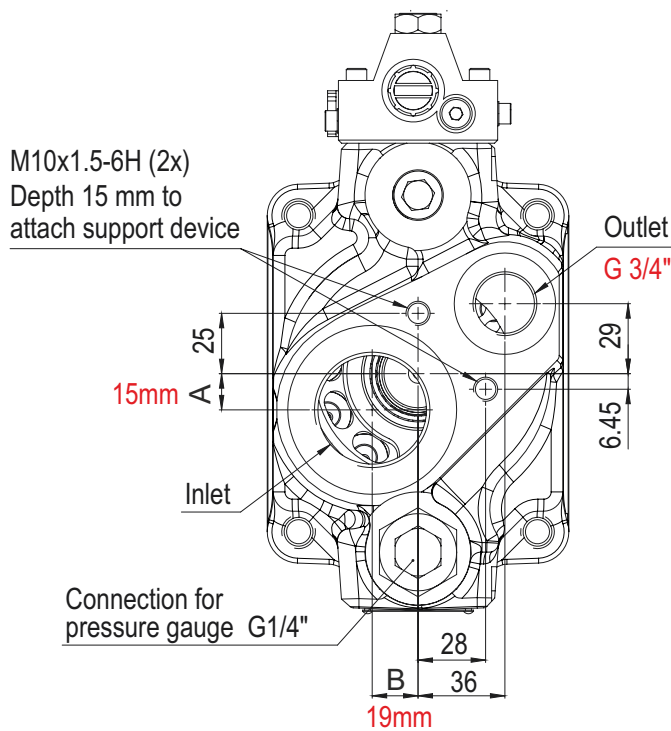

**CW**

**View from F**

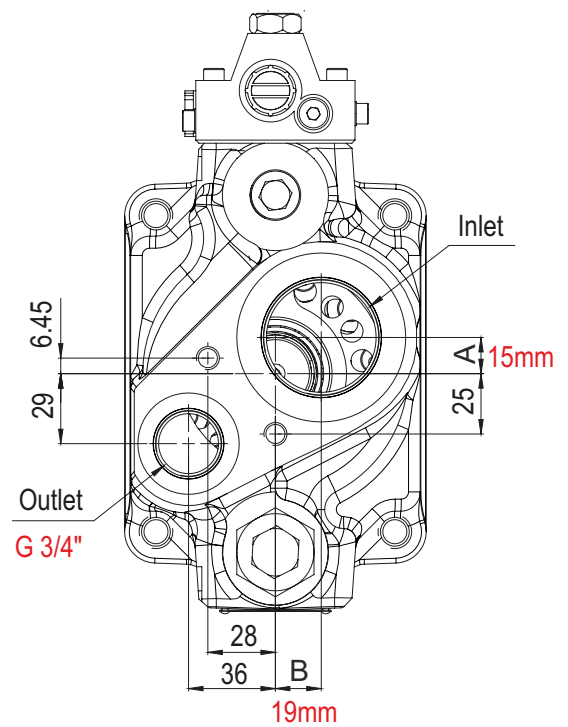

**CCW**

# A12V - 75 cc Variable Piston Pump

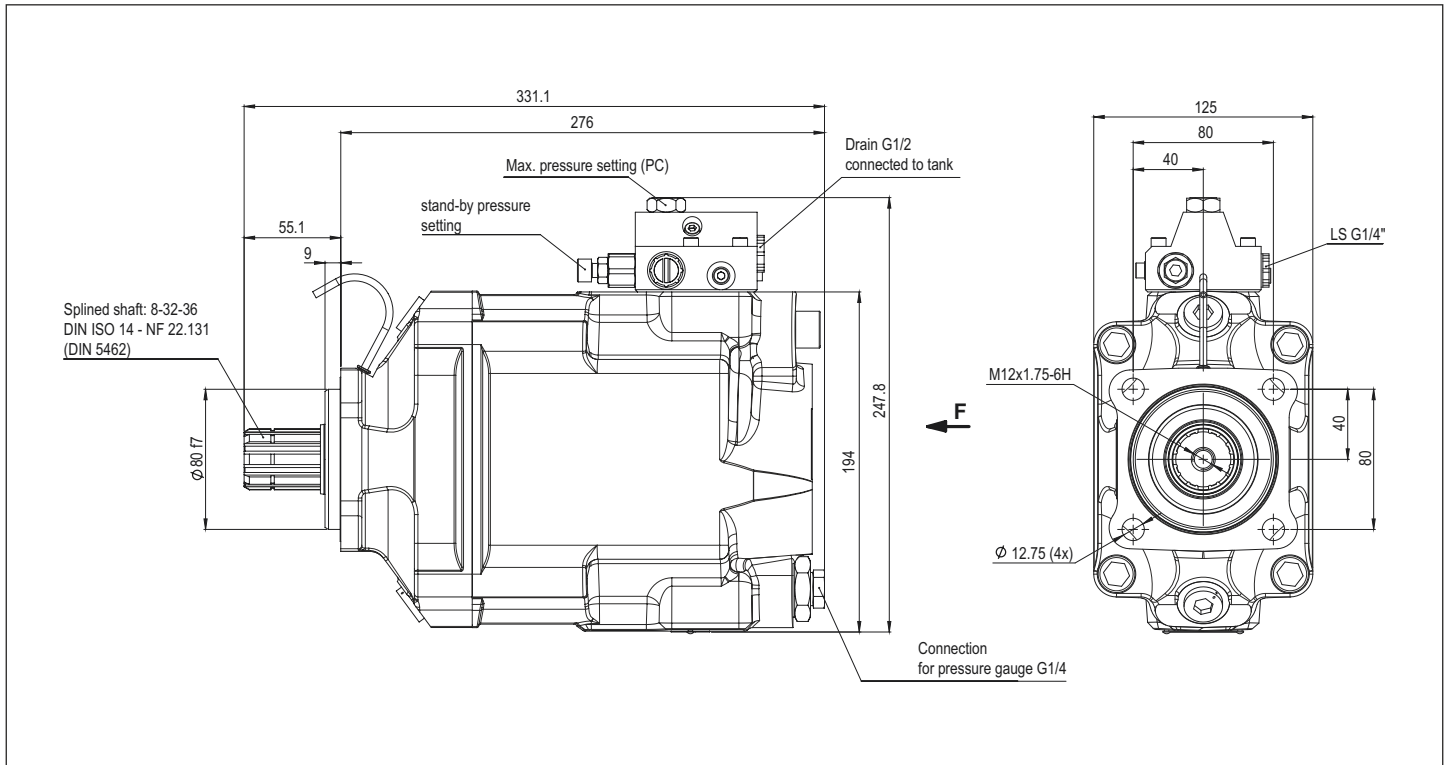

**View from F**

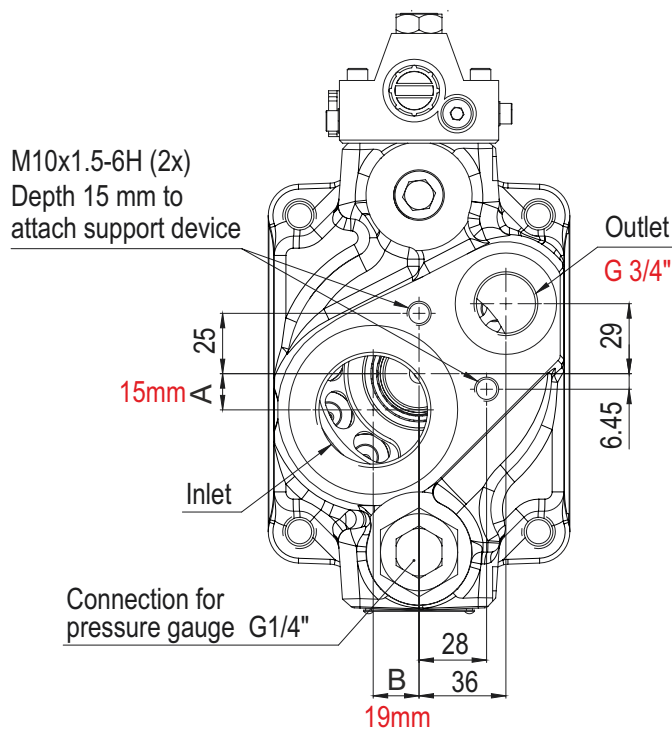

**CW**

**View from F**

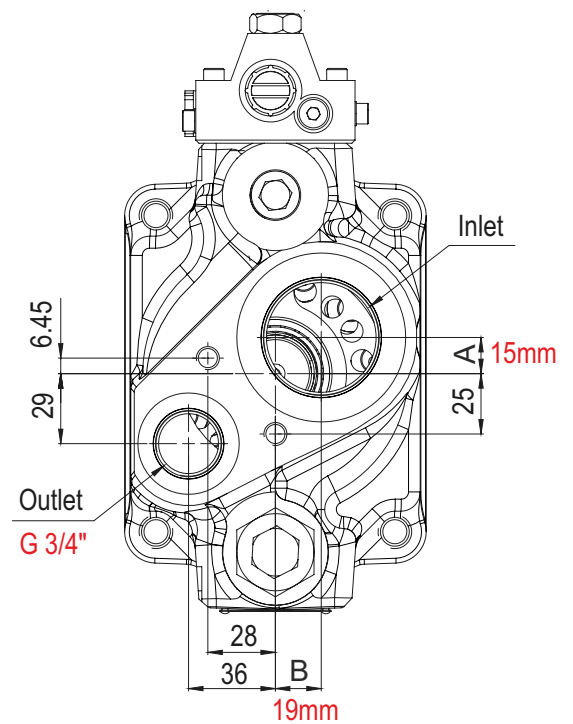

**CCW**

# A12V - 92 cc Variable Piston Pump

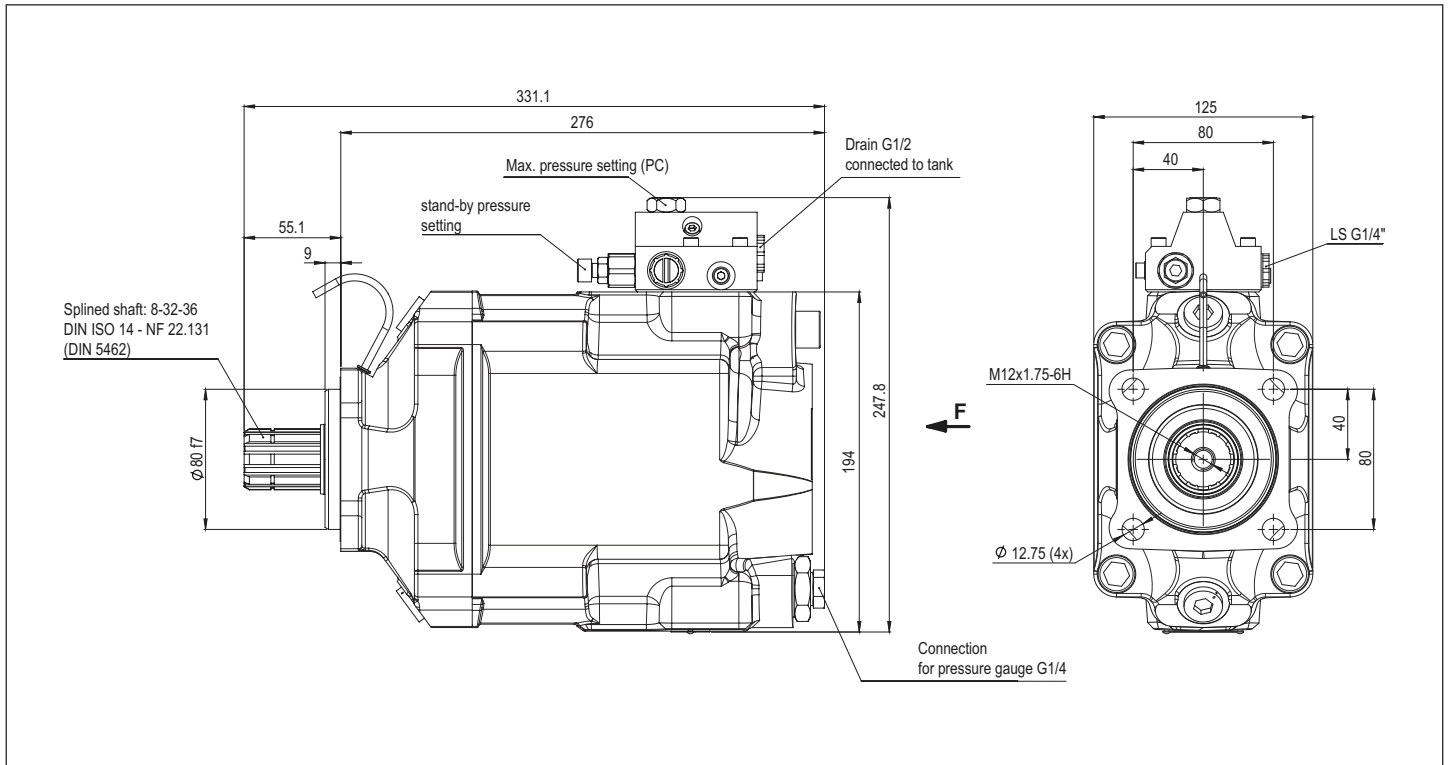

**View from F**

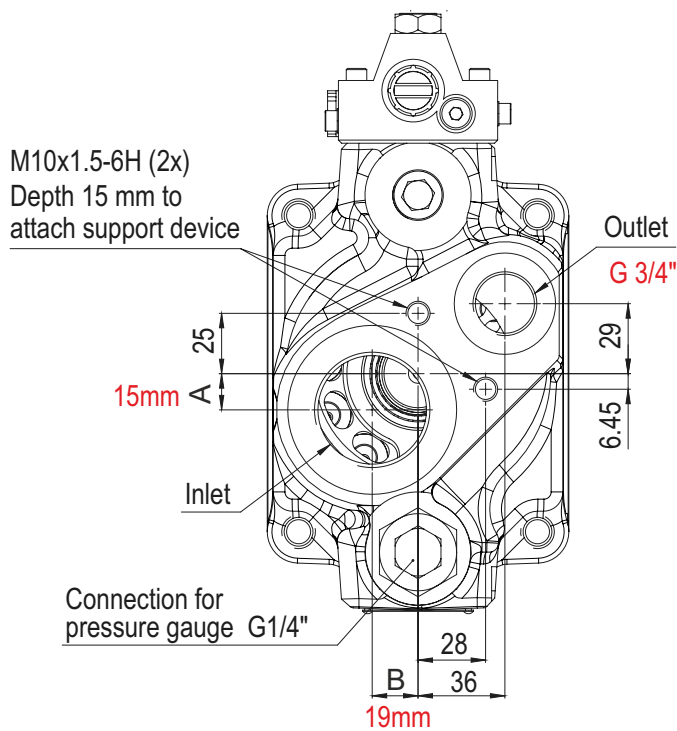

**CW**

**View from F**

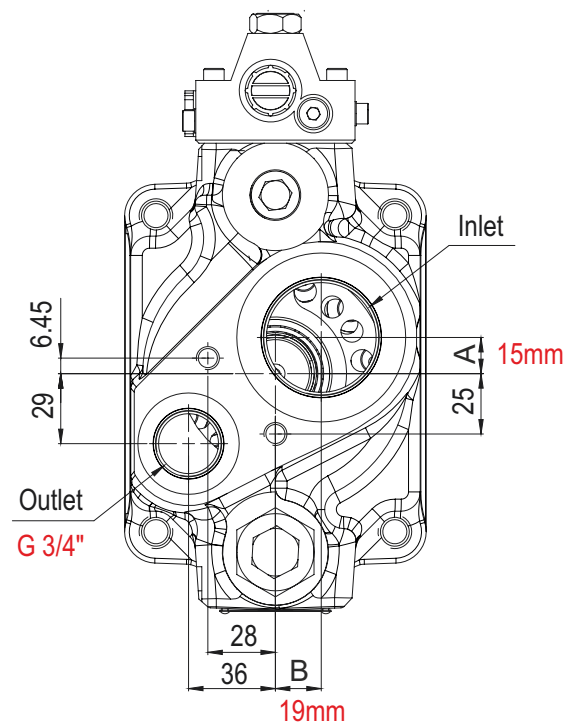

**CCW**



# A12V - 120 cc Variable Piston Pump

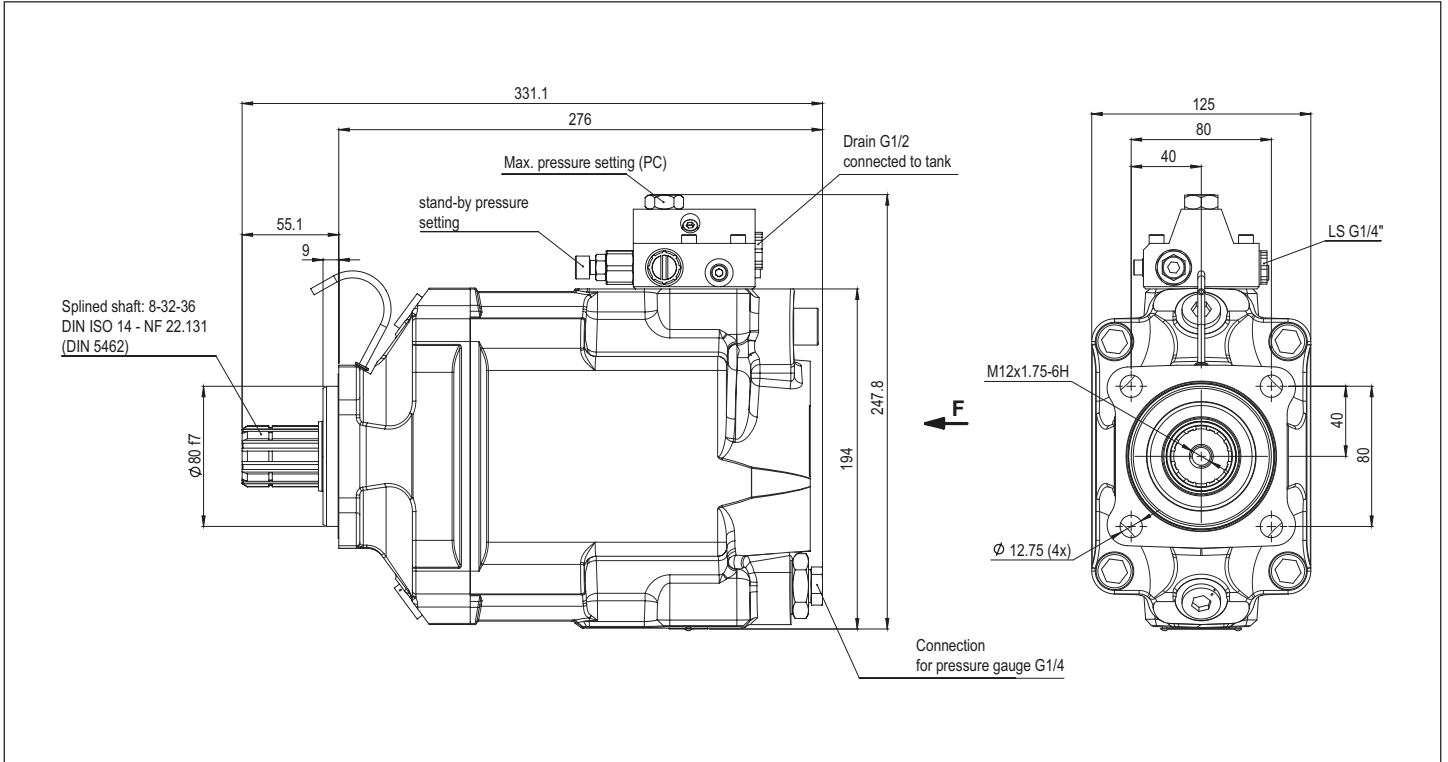

**View from F**

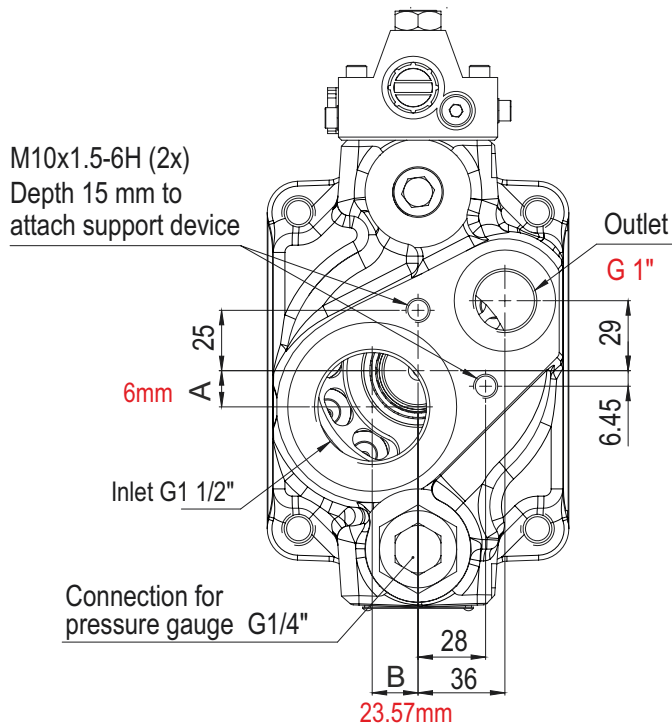

**CW**

**View from F**

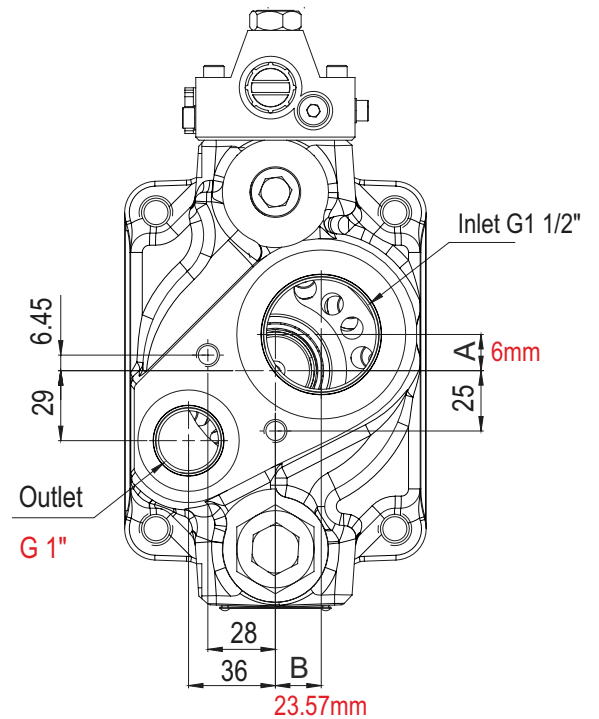

**CCW**

# A12V - 130 cc Variable Piston Pump

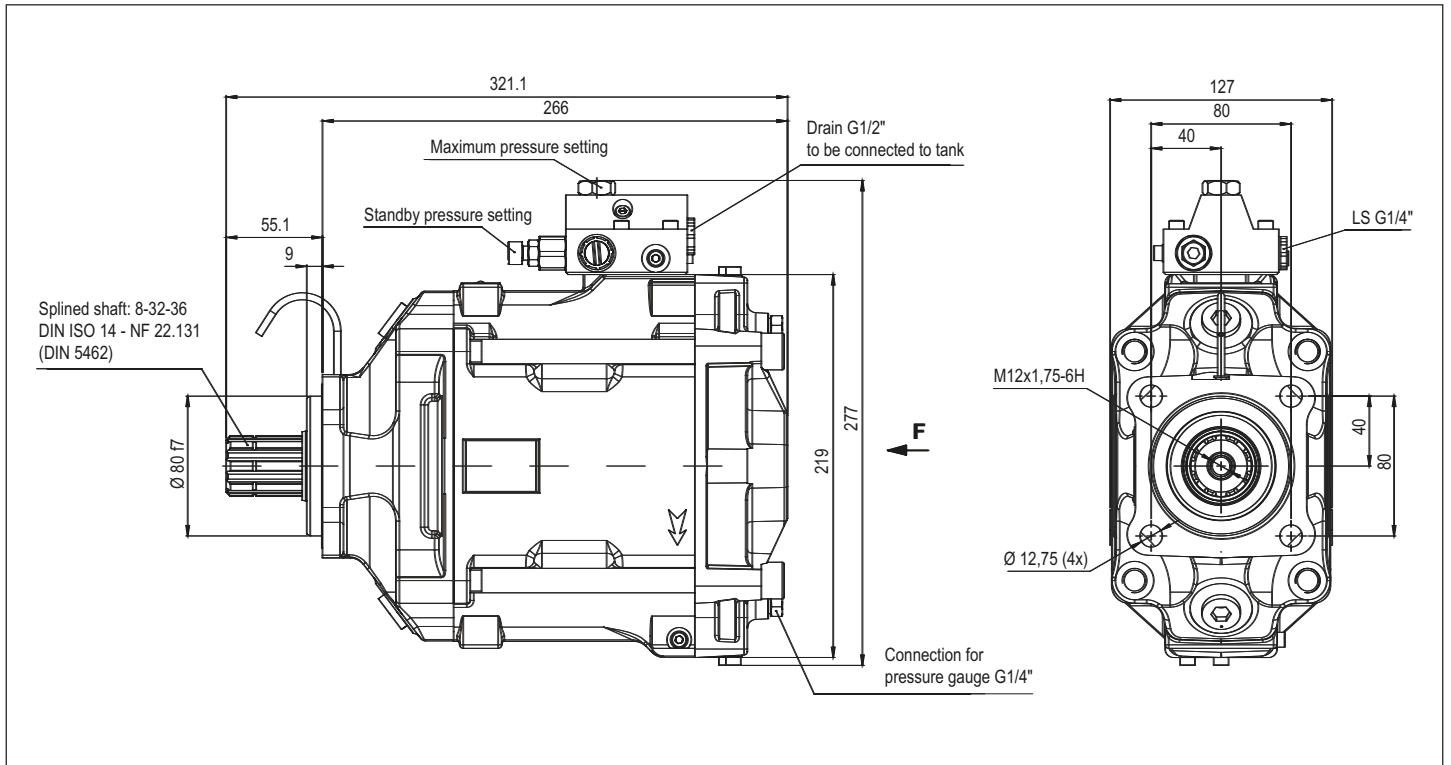

View from F

View from F

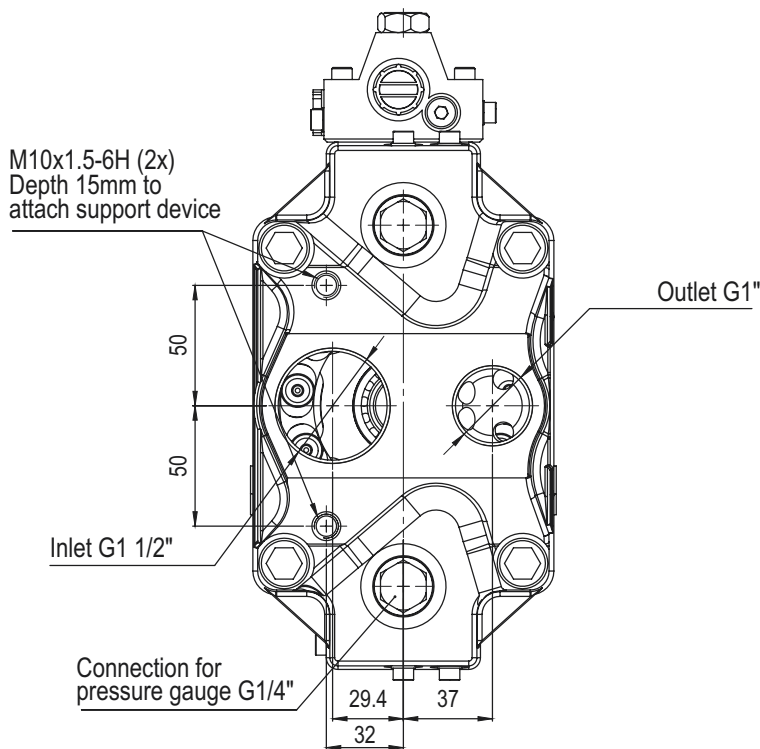

**CW**

**CCW**

# A12V - 150 cc Variable Piston Pump

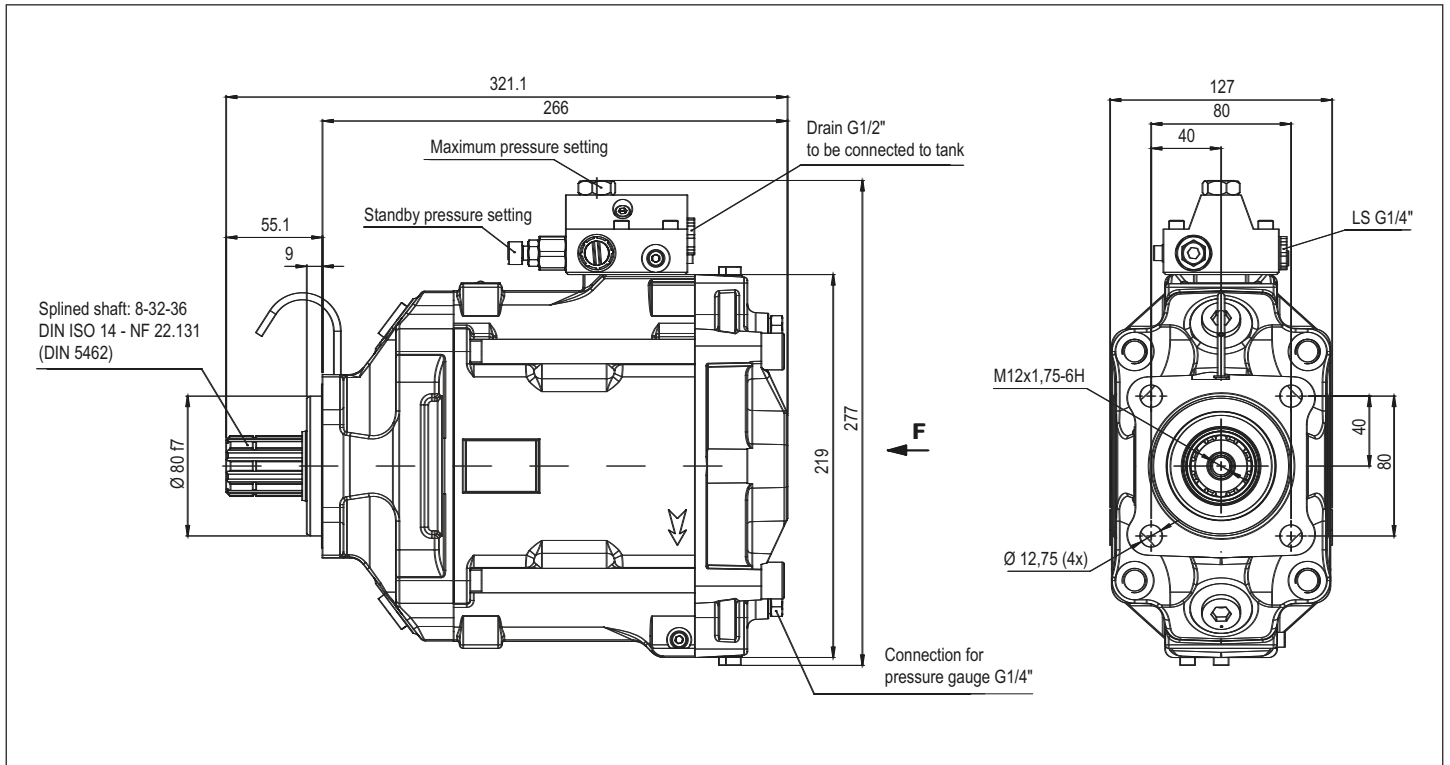

View from F

View from F

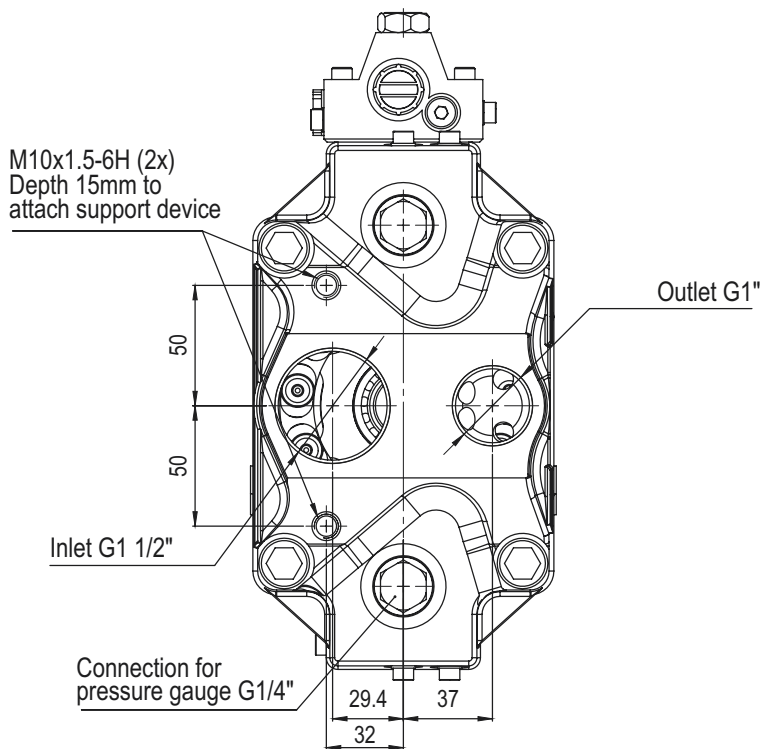

**CW**

**CCW**

## Suction Fittings for A12V Hydraulic Piston Pumps

### 90° elbow fittings, swivel

Reference	A	Ø B	C	D	E	F	Pump type
90001	G 1 1/2"	40	60	17	61	77	variable
90002	G 1 1/2"	50	60	17	65	82	variable

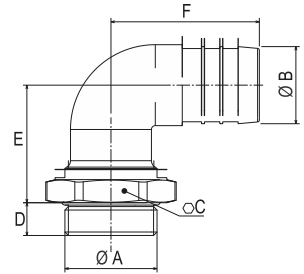

### Straight Fittings

Reference	A	Ø B	C	D	E	Pump type
50001	G 1 1/2"	40	55	16	52	variable
50002	G 1 1/2"	48	55	16	64	variable
50003	G 1 1/2"	60	65	16	67	variable
50004	G 1 1/2"	63.5	65	16	67	variable
50005	G 1 1/2"	76.2	80	16	87	variable

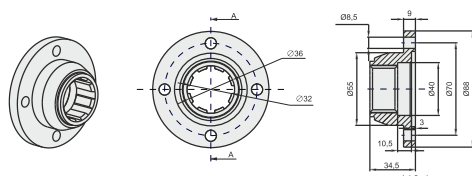
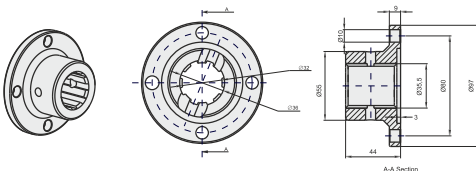
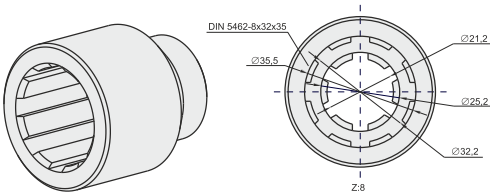
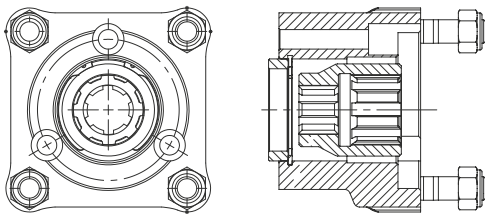
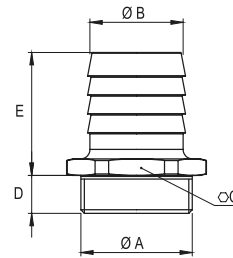

	<b>Inlet Fittings &amp; Installation Parts</b> - Split Flange - Seal - Screw
	<b>By-Pass Valves</b> - 12 V - 24 V
	<b>Hydraulic Adapters</b> - PTO Piston Pump Adapter - PTO Gear Pump Adapter - Long / Short Adapter
	<b>Flanges</b> - 1120 ( 6 Spline ) - 1120 ( 8 Spline ) - 1300 ( 6 Spline ) - 1300 ( 8 Spline )
	<b>Couplers</b> - 6 x 8 Couplars - 6 x 8 Couplars ( Long ) - 8 x 8 Couplars - 8 x 8 Couplars ( Long )

**Calculation of power to be supplied to the shaft as a function of flow and pressure**

$$P = \frac{\Delta P \times Q}{600 \times \eta_{\text{global}}}$$

Calculation of torque to determine PTO,  
as a function of the displacement and the pressure

$$C = \frac{\text{Cyl} \times \Delta P}{62.8 \times \eta_{\text{meca}}}$$

With:

- P = Hydraulic power in kW
- $\Delta P$  = Differential pressure in bar
- Q = Flow in l/min
- C = Torque in N.m
- Cyl = Displacement in cc/rev
- $\eta_{\text{meca}}$  = Mechanical efficiency
- $\eta_{\text{global}}$  = Mechanical efficiency + volumetric efficiency

**Ideal installation**

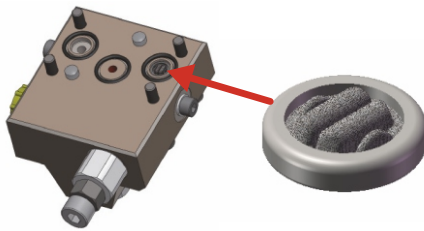
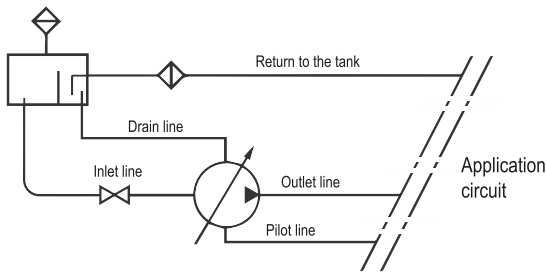

**Force on pump shaft**

Fr : Acceptable max. radial force = 3000 N

Fa : Acceptable axial force = 1600 N.

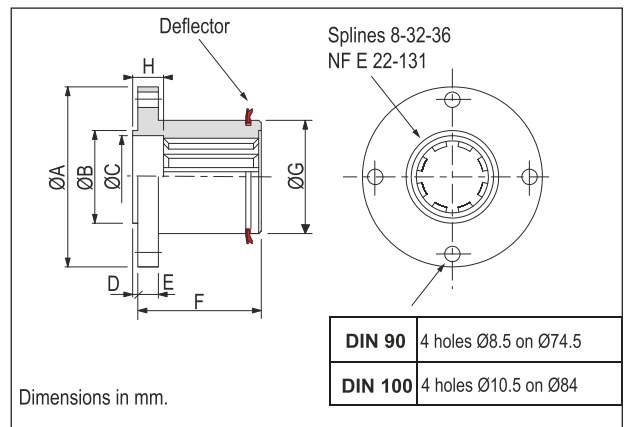
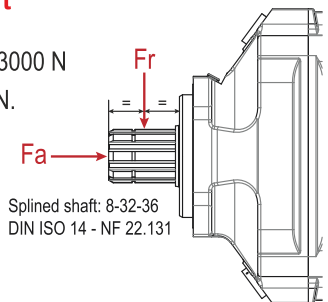

Type	ØA	ØB	C	D	E	F	ØG	H
<b>DIN 90</b>	90	47	43	2	10	62	55	15
<b>DIN 100</b>	100	57	43	2	10	64	55	15

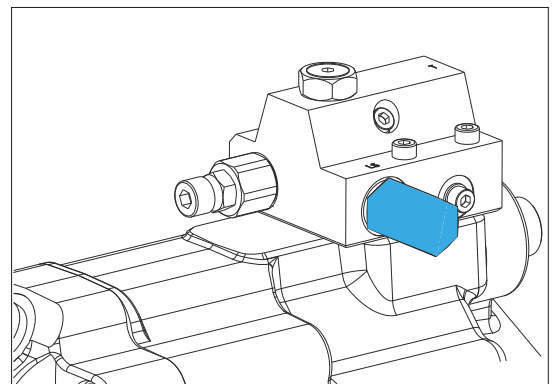
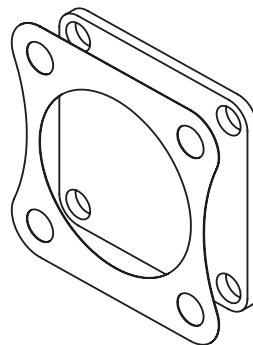
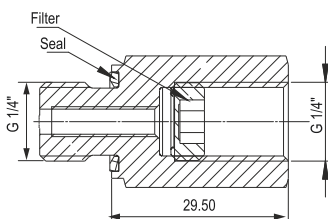
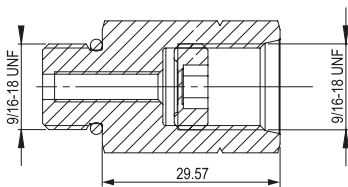

## Torque and Flow

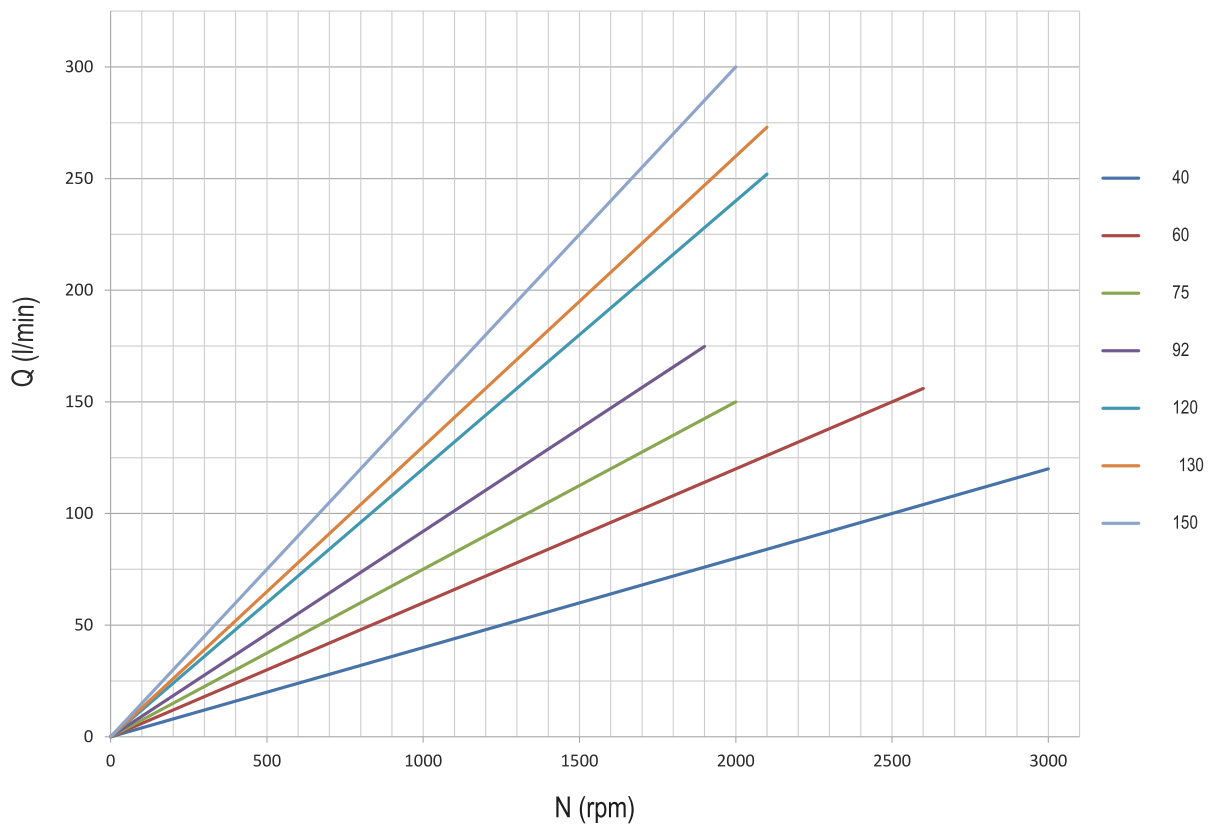
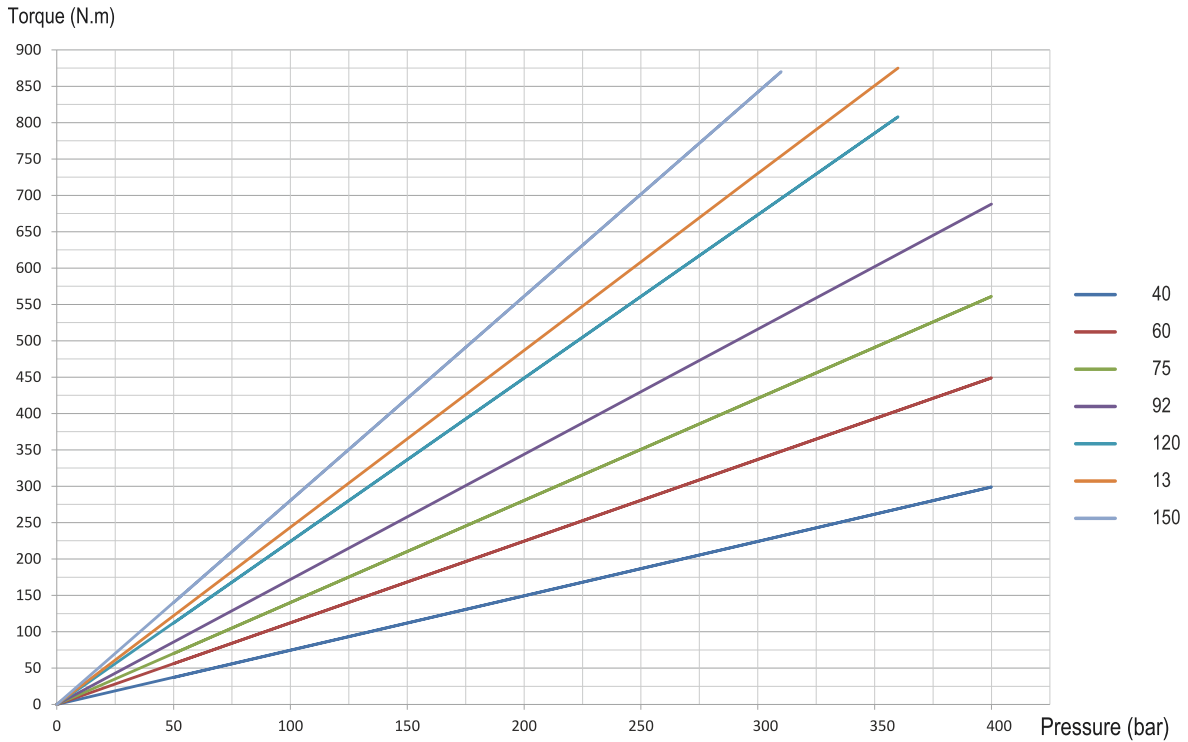



## Accessories

### FCV - FLUID VALVE CIRCULATION

The fluid circulation (FCV) is designed for applications where the hydraulic variable displacement pump is used in standby mode for a long period of time, for example engine PTO, to protect the pump against overheating.

- The valve flow varies between 20 and 22 l/min for a  $\Delta P$  at 30 bar.
- Maximum pressure is 420 bar.
- The closing pressure is 2 bar min. and 7 bar max.

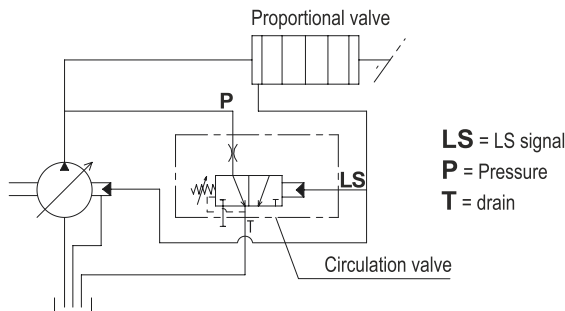
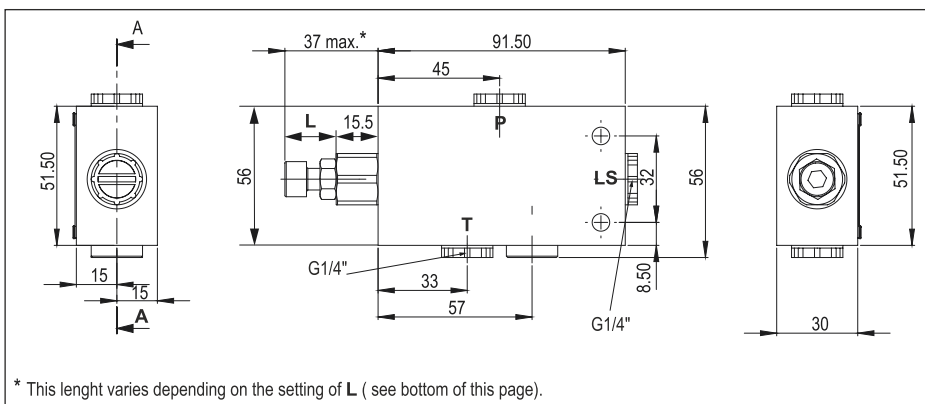
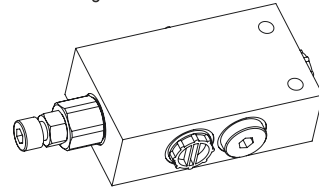

### Setting of the control pressure

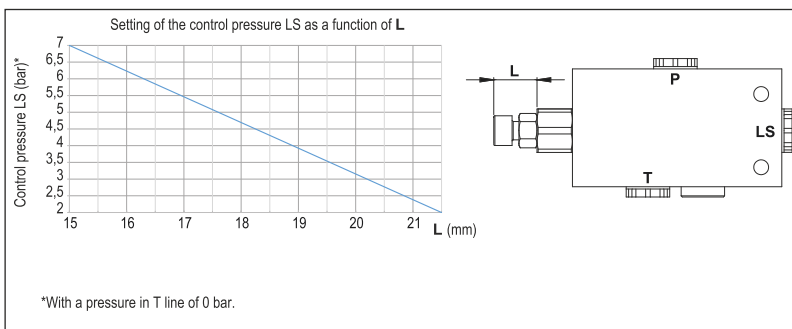

40° bent axis design giving high power, small overall dimensions, optimum efficiency and economic design. Flange and shaft designed for direct mounting on truck gearbox PTO's. The fixed displacement bent axis pumps generates a hydraulic fluid flow. It is designed for use in trucks, commercial vehicles and all stationary hydraulic applications. The Pump a fixed pump with rotary group in bent-axis design open circuits. Flow is proportional to drive speed and displacement.

For axial piston units with bent-axis design, the Pistons are arranged diagonally with respect to the drive shaft. The pump covers the whole displacement range 5 to 130 cm<sup>3</sup>/rev. The pump has been developed with modern styling and design to satisfy market demand as to designed new generation plate and pistons with give high flow performance, high pressures with high efficiency and very small dimensions.

The pump is available both to DIN and SAE world standards and can be mounted either directly at the gear box or via a drive shaft. If necessary it can also be augmented with a by-pass valve. Other brand bent axis pumps compatible and interchangeable with DIN Hydraulic Piston Pumps. Refer to the data sheet and confirmation for the technical data, operating conditions and operating limits of the bent axis piston pumps.

Formulas			
<b>Pump Output Flow</b>	GPM	$GPM = (\text{Speed (rpm)} \times \text{disp. (cu. in.)}) / 231$	$GPM = (n \times d) / 231$
<b>Pump Input Horsepower</b>	HP	$HP = GPM \times \text{Pressure (psi)} / 1714 \times \text{Efficiency}$	$HP = (Q \times P) / 1714 \times E$
<b>Pump Efficiency</b>	E	Overall Efficiency = Output HP / Input HP	$E_{\text{Overall}} = \text{HPOut} / \text{HPIn} \times 100$
		Overall Efficiency = Volumetric Eff. × Mechanical Eff.	$E_{\text{Overall}} = \text{EffVol.} \times \text{EffMech.}$
<b>Pump Volumetric Efficiency</b>	E	Volumetric Efficiency = Actual Flow Rate Output (GPM) / Theoretical Flow Rate Output (GPM) × 100	$\text{EffVol.} = \text{QAct.} / \text{QTheo.} \times 100$
<b>Pump Mechanical Efficiency</b>	E	Mechanical Efficiency = Theoretical Torque to Drive / Actual Torque to Drive × 100	$\text{EffMech} = \text{TTheo.} / \text{TAct.} \times 100$
<b>Pump Displacement</b>	CIPR	$\text{Dsplcmnt (In.}^3 \text{ / rev.)} = \text{Flow Rate (GPM)} \times 231 / \text{Pump RPM}$	$\text{CIPR} = \text{GPM} \times 231 / \text{RPM}$
<b>Pump Torque</b>	T	Torque = Horsepower × 63025 / RPM	$T = 63025 \times \text{HP} / \text{RPM}$
		Torque = Pressure (PSIG) × Pump Displacement (CIPR) / 2π	$T = P \times \text{CIPR} / 6.28$

- Horsepower for driving a pump** : For every 1 hp of drive, the equivalent of 1 gpm @ 1500 psi can be produced.
- Horsepower for idling a pump** : To idle a pump when it is unloaded will require about 5% of it's full rated power
- Wattage for heating hydraulic oil** : Each watt will raise the temperature of 1 gallon of oil by 1° F. per hour.
- Flow velocity in hydraulic lines** : Pump suction lines 2 to 4 feet per second, pressure lines up to 500 psi - 10 to 15 ft./sec., pressure lines 500 to 3000 psi - 15 to 20 ft./sec.; all oil lines in air-over-oil systems; 4 ft./sec.

## Complete Product Range

### Bent Axis Piston Motors

- A9MD** (DIN) Bent Axis Motors
- A9MO** (ISO) Bent Axis Motors
- A9MS** (SAE) Bent Axis Motors
- A9ML** (SAE2) Bent Axis Motors
- A9MF** (Fixed Plugin) Bent Axis Motors
- A10M** (HYBRID) Bent Axis Motors
- A7GM** Hydraulic Gear Motors
- A7GMT** Tandem Hydraulic Gear Motors

### Bent Axis Piston Pumps

- A8PA** (Aluminum) Bent Axis Pumps
- A8PD** (DIN) Bent Axis Pumps
- A8PO** (ISO) Bent Axis Pumps
- A8PS** (SAE) Bent Axis Pumps
- A8PF** (Fixed Plugin) Bent Axis Pumps
- A10** (HYBRID) Bent Axis Pumps
- A11** (ISO2) Bent Axis Pumps
- A11** (SAE2) Bent Axis Pumps

### Variable Displacement Pumps

- A12V** Variable Displacement Piston Pumps

### Dual Flow Piston Pumps

- A8PL** (DIN) Dual Flow Pumps

### Axial Piston & Gear Pumps

- A4PP** Axial Hydraulic Piston Pumps
- A6HP** High Pressure Piston Pumps
- A7GP** Hydraulic Gear Pumps
- A7GPT** Tandem Hydraulic Gear Pumps

### Valve (ByPass) (Flushing) (Cavitation)

- Circulation Valve
- ByPass Valve
- Anti-Cavitation Valve
- Flushing Valve
- LS Valve
- AntiShock Valve
- Speed Sensor

### Hydraulic Spare Parts

- Suction Fittings
- Couplers
- Adapters
- Flanges
- Power Take Off
- Monoblock Valve
- Section Valve

## Hydraulic Pumps, Motors

Bent Axis Hydraulic Piston Motors, Bent Axis Hydraulic Piston Pumps, Piston Pumps, Variable Displacement Piston Pumps, Variable Displacement Piston Motors, Axial Piston Pumps, High Pressure Piston Pumps, Gear Pumps, Gear Motors, Hydraulic Valve.

[www.goldhydraulics.com](http://www.goldhydraulics.com)

### Address;

**HYDROGOLD HİDROLİK PNM. MAK. SAN. TİC. LTD. ŞTİ.**

**Address; (Fabrika, İmalat)**

Fevzicakmak Mah. Sıla Cad. Kobisan 3 San. Sit.

No: 73 / C Karatay – Konya, PO Code; 42050, Türkiye

**Address; (Montaj, Sevkiyat)**

Fevzicakmak Mah. Sıla Cad. Kobisan 3 San. Sit.

No: 71 / AD Karatay – Konya, PO Code; 42050, Türkiye

**Phone; +90 551 148 26 88**

[mail@goldhydraulics.com](mailto:mail@goldhydraulics.com)