

A8PL (DIN) Dual Flow Bent Axis Piston Pump

Twin Flow Bent Axis Hydraulic Piston Pumps, Dual Flow, Dual Output.
High Pressure, High Rotational Speed, High Efficiency, Slim Design.
Aluminum Pump Body, Re-Designed in 2025.

Designation;

46/46-R, 46/46-L, 53/53-R, 53/53-L,
68/68-R, 68/68-L, 70/70-R, 70/70-L,
76/76-R, 76/76-L.

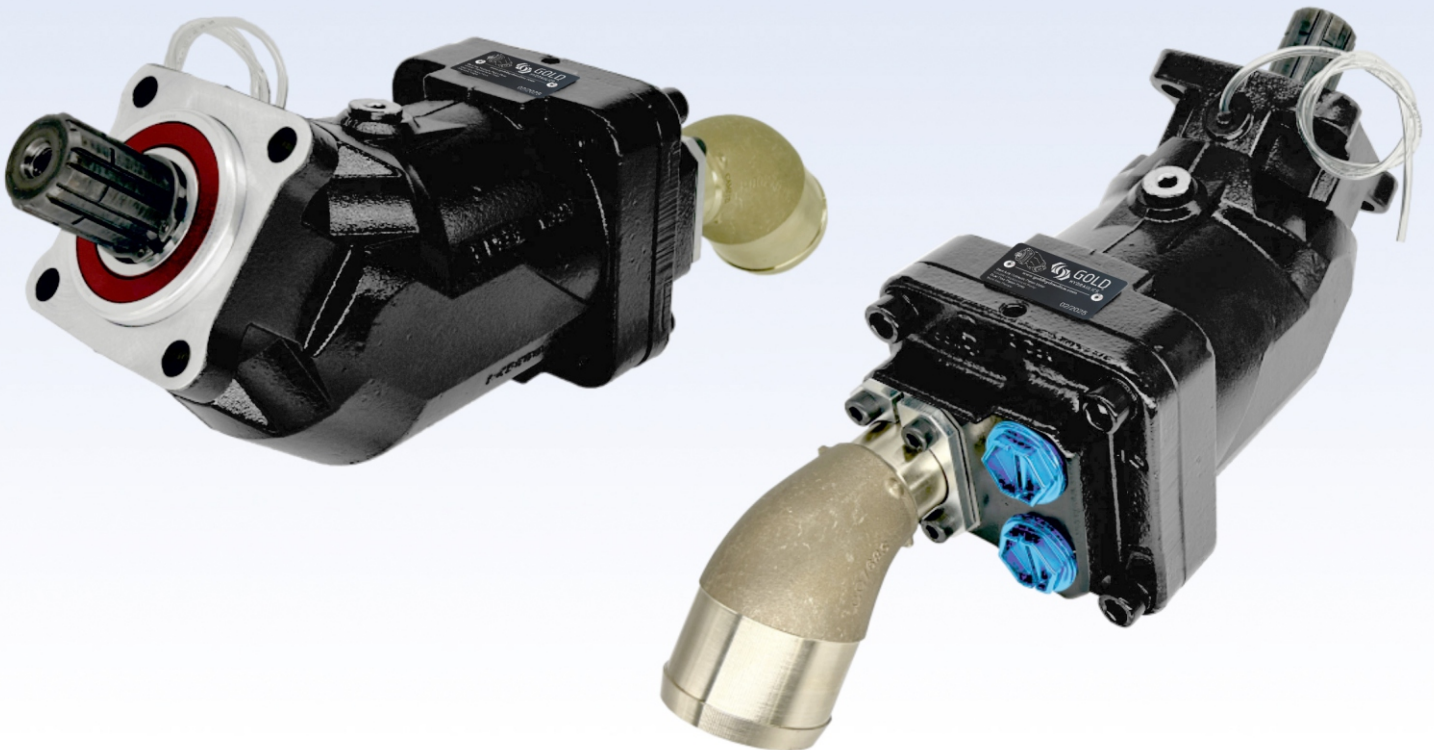

www.goldhydraulics.com

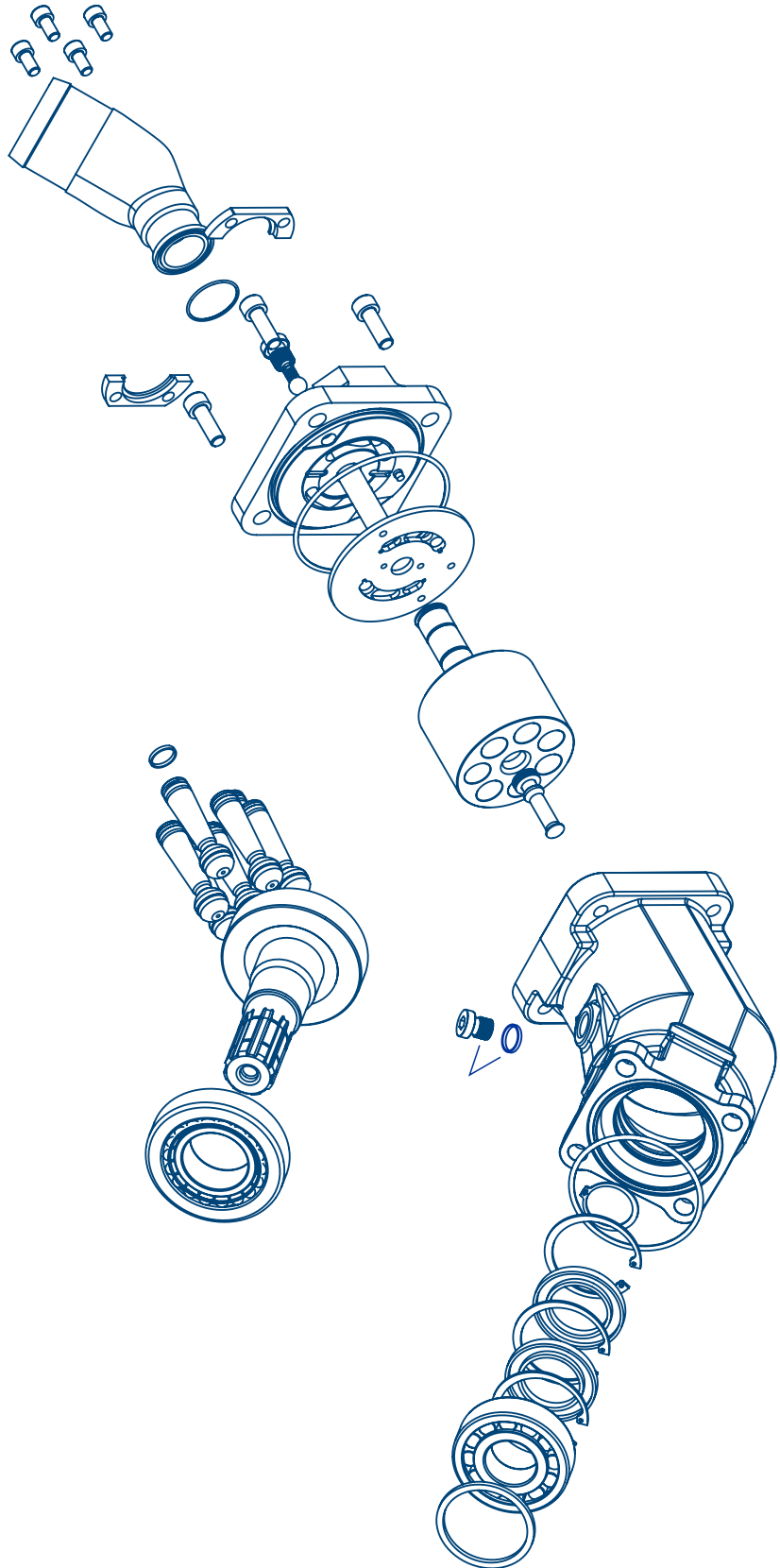

A8PL 46/46-R
A8PL 46/46-L

A8PL 53/53-R
A8PL 53/53-L

A8PL 68/68-R
A8PL 68/68-L

A8PL 70/70-R
A8PL 70/70-L

A8PL 76/76-R
A8PL 76/76-L

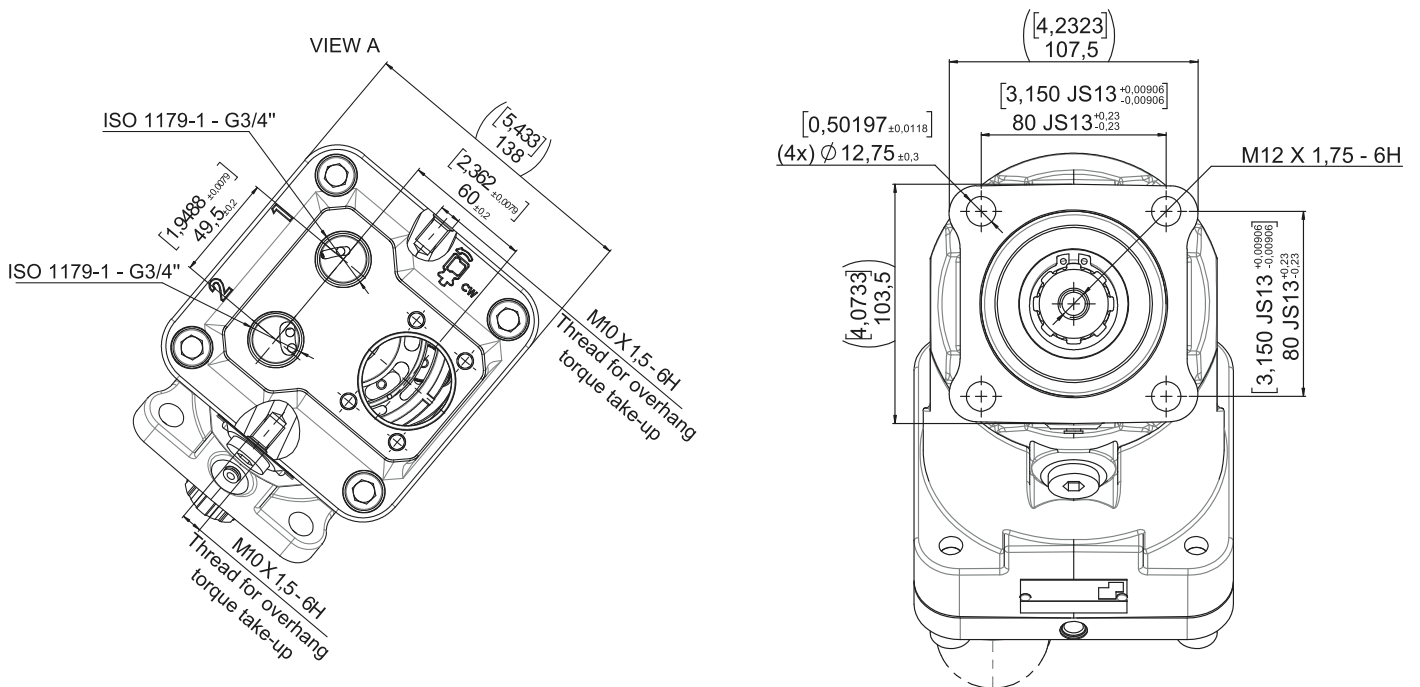
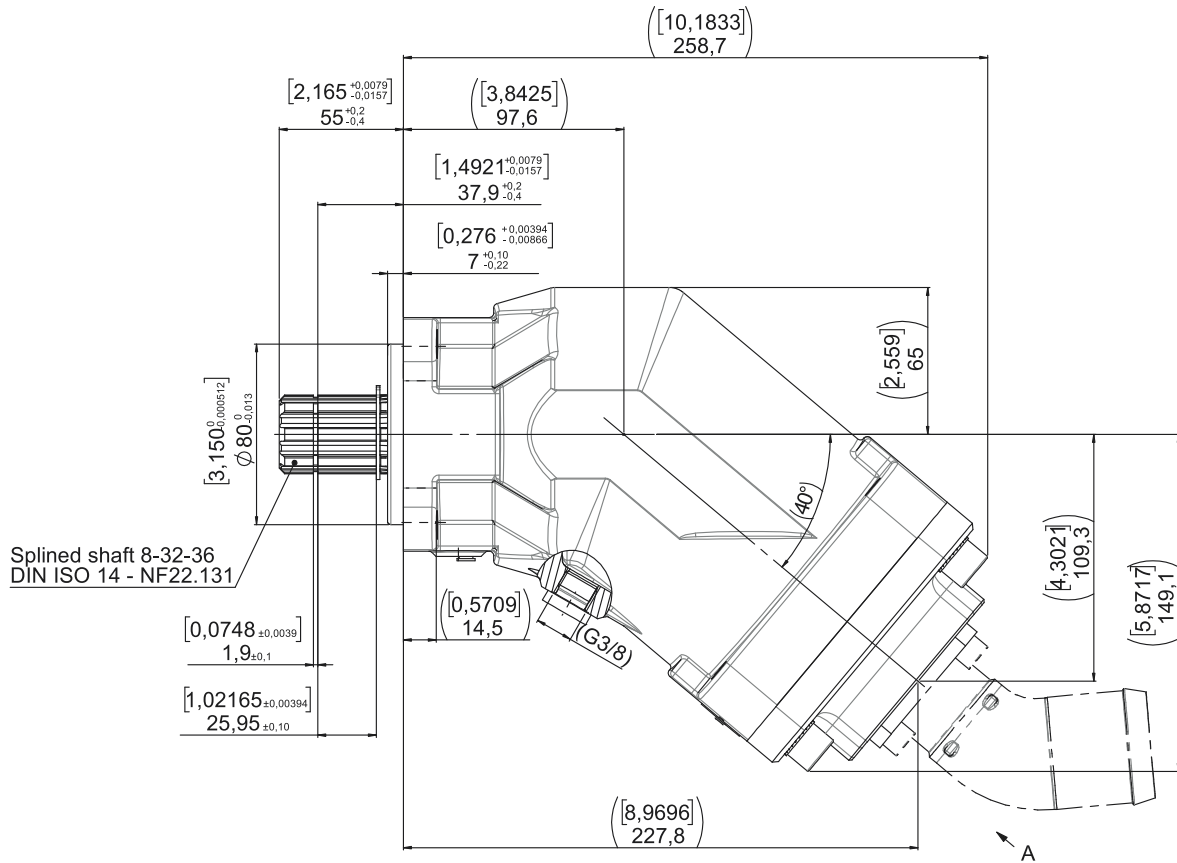

Specifications

Frame size	46/46	53/53	68/68	70/70	76/76
Displacement [cm ³ /rev]					
Port A	46	55	68	69	75
Port B	45	52	69	71	76
Max operating pressure [bar]					
continuous	380	380	380	380	380
intermittent ³⁾	420	420	420	420	420
Mass moment of inertia J [kgm ²]	0.0092	0.0091	0.0091	0.0090	0.0104
Max Shaft speed [rpm]					
(unloaded pump; low pressure)	2550	2550	2550	2550	2550
Max selfpriming speed [rpm]					
Ports A ¹⁾ and B ¹⁾ pressurised	1800	1800	1800	1800	1650
Port A ¹⁾ unloaded, pressure in port B	2100	2100	2100	2100	2100
Max input power ²⁾ [kW]	100	127	100	126	131
Weight [kg]	19	19	19	19	19

Flow vs. shaft speed (theoretical)

Pump speed [rpm]	800	1000	1200	1400	1600	1800	1900	2000	2100
flow [l/min] 53/53									
Port A	43	54	65	76	86	97	-	-	-
Port B	42	52	62	73	83	94	99	104	109
Total (A + B) ports	85	106	127	149	169	191	-	-	-
Note:46/46 values is 80 % of 53/53 values 70/70 values is 130 % of 53/53 values									
flow [l/min] 70/35									
Port A	55	69	83	97	110	124	-	-	-
Port B	29	36	43	50	58	65	68	72	76
Total (A + B) ports	84	105	126	147	168	189	-	-	-
Note: 55/28 values is 80 % of 70/35 values									

Shaft torque vs. pressure (theoretical)

Pressure [bar]	150	200	250	300	350
torque [Nm] 53/53					
Port A	129	171	214	257	300
Port B	124	165	206	248	289
Total (A + B) ports	253	336	420	505	589
Note:46/46 values is 80 % of 53/53 values 70/70 values is 130 % of 53/53 values					
torque [Nm] 70/35					
Port A	164	219	274	329	383
Port B	86	114	143	171	200
Total (A + B) ports	250	333	417	500	583
Note: 55/28 values is 80 % of 70/35 values					

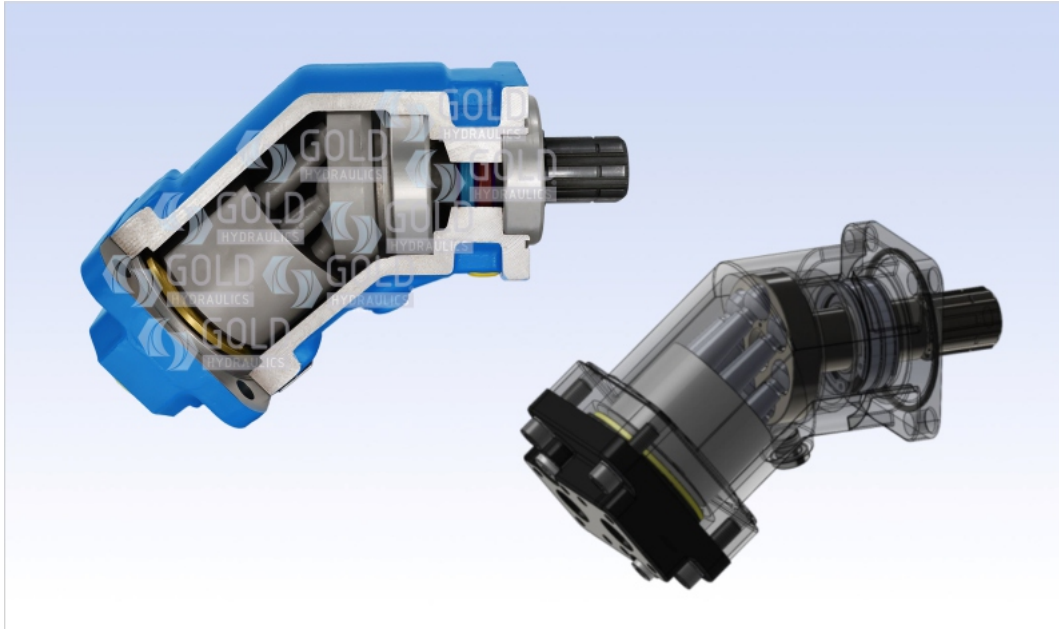

Design and Function

Dual Flow Pump is a Piston Pump with spherical pistons. Including Piston Rings. The pistons are working at the angle of 40 degree to the shaft. When the shaft rotates, the pistons move up and down in the cylinder barrel, forcing the oil to pass from the inlet port to the outlet in the end cap.

A ring gear connects the cylinder barrel to the drive shaft, causing these to rotate at the same speed.

A barrel support with a spring presses the cylinder barrel against the end cap. An internal connection from the housing to the suction port eliminates a separate draining line to the tank. Double Flow Pumps provided with shaft and connection flange that fits direct to PTO's with ZF Standard.

Inlet/Suction Fittings included with Dual Flow Piston Pumps.
User guide and Installation Instructions included.

Sizes;

A8PL 46/46-R A8PL 46/46-L
A8PL 53/53-R A8PL 53/53-L

A8PL 68/68-R A8PL 68/68-L
A8PL 70/70-R A8PL 70/70-L
A8PL 76/76-R A8PL 76/76-L

Conversion factors

1 kg = 2.2046 lb
1 N = 0.22481 lbf
1 bar = 14.504 psi
1 l = 0.21997 UK gallon
1 l = 0.26417 US gallon
1 cm³ = 0.061024 in³
1 m = 3.2808 feet
1 mm = 0.03937 in
9/5 °C + 32 = °F

Pump Performance Data

Model Series	Max. Displacement in ³ /rev (cc/rev)	Outlet Pressure PSI (BAR)	Drive Speed RPM	Flow** @ 1800 RPM		Max. Input Power HP (KW)
				Port A GPM (LPM)	Port B GPM (LPM)	
46/46	2.62/2.50 (46/45)	5800 (420)	1800	20.4 (77.2)	19.5 (73.8)	118 (88.0)
53/53	3.36/1.71 (53/23)	5800 (420)	1800	26.1 (98.6)	13.3 (50.3)	118 (88.0)
68/68	3.30/3.17 (68/69)	5800 (420)	1800	25.5 (96.5)	24.8 (93.9)	147 (109.8)
70/70	4.21/2.20 (69/71)	5800 (420)	1800	32.7 (123.8)	17.2 (65.1)	147 (109.8)
76/76	4.15/4.15 (76/75)	5800 (420)	1650	32.3 (122.3)	32.3 (122.3)	150 (111.9)

45° elbow fittings kit

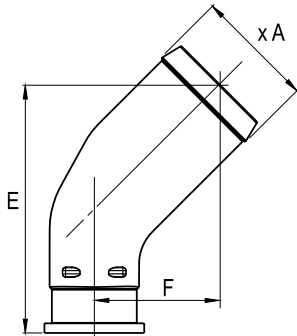

Reference	Ø hose	Ø A	E	F
450039	1 1/2"	39.1	91.7	46.7
450043	42	43	91.7	46.7
450046	1 3/4"	46	91.7	46.7
450051	2"	51.8	108.4	54.4
450064	2 1/2"	64.5	125.2	62.2

90° elbow fittings kit

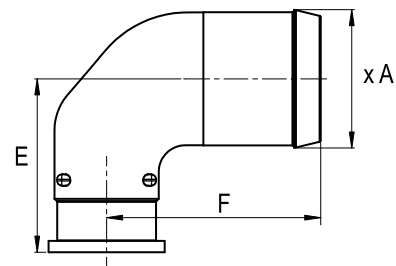

Reference	Ø hose	Ø A	E	F
900039	1 1/2"	39.1	58.6	79.5
900051	2"	51.8	64.9	80.2
900064	2 1/2"	64.5	71.3	87.5

Markets

Applications

Forestry	Knuckle Boom Loader, Cranes, Mowers / Cutters
Construction	Off-Highway Trucks, Fan Drives
Mining	Dump Trucks
Material Handling	Truck Mounted Cranes, Lift Trucks
Recycling	Vaccum Truck Systems, Refuse Trucks - ASL, Rear Loaders
Military	

DUAL FLOW PUMP bypass valve

- A dual/twin pump fitted with a bypass valve can be utilised in applications where the pump is operating constantly i.e. when the pump is driven from the crankshaft through a cardan shaft, or when it is installed on an engine-PTO. In addition, it can be used when, temporarily, one of the two circuits is not required; the power loss is thus reduced as the non-required flow is not forced through lines and 'open center' valves.
- The DUAL bypass valve should be disengaged during transportation when the pump is operating constantly and the engine is running at max rpm; the hydraulic system is not sized for the large flow that would otherwise go through it.
- The DUAL valve connects the outlet and inlet ports of the pump, and only a small oil flow goes through the system and to the reservoir.
- The valve is installed directly on top of the pump port surface with 'banjo' fittings and two cap screws (refer to the split view to the right).
- As the DUAL valve is symmetrical it can be 'turned 180°' so as not to interfere with chassis components. The valve can accommodate left hand as well as right hand rotating pumps.
- The valve can only be engaged or disengaged (through the 24 or 12 VDC solenoid) at low system pressures (below 20 bar).

IMPORTANT INFORMATION

- In order to secure a cooling flow through the system, a separate drain line **must** be connected from the BPV-pump drain line fitting (shown in the split view) directly to tank; refer also to the schematic.
- The pressure connectors must be tightened (to 50 Nm) before the suction fitting clamp screws are tightened.

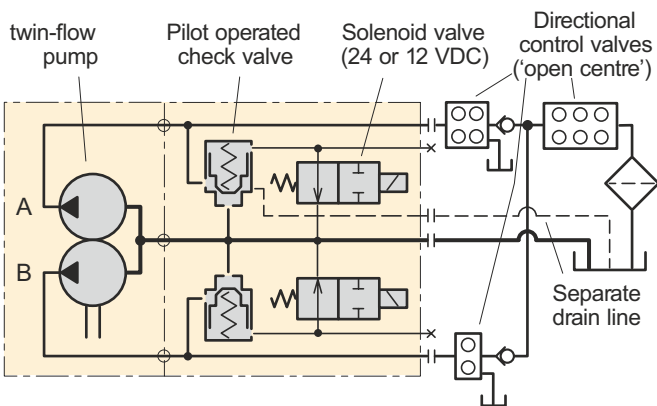
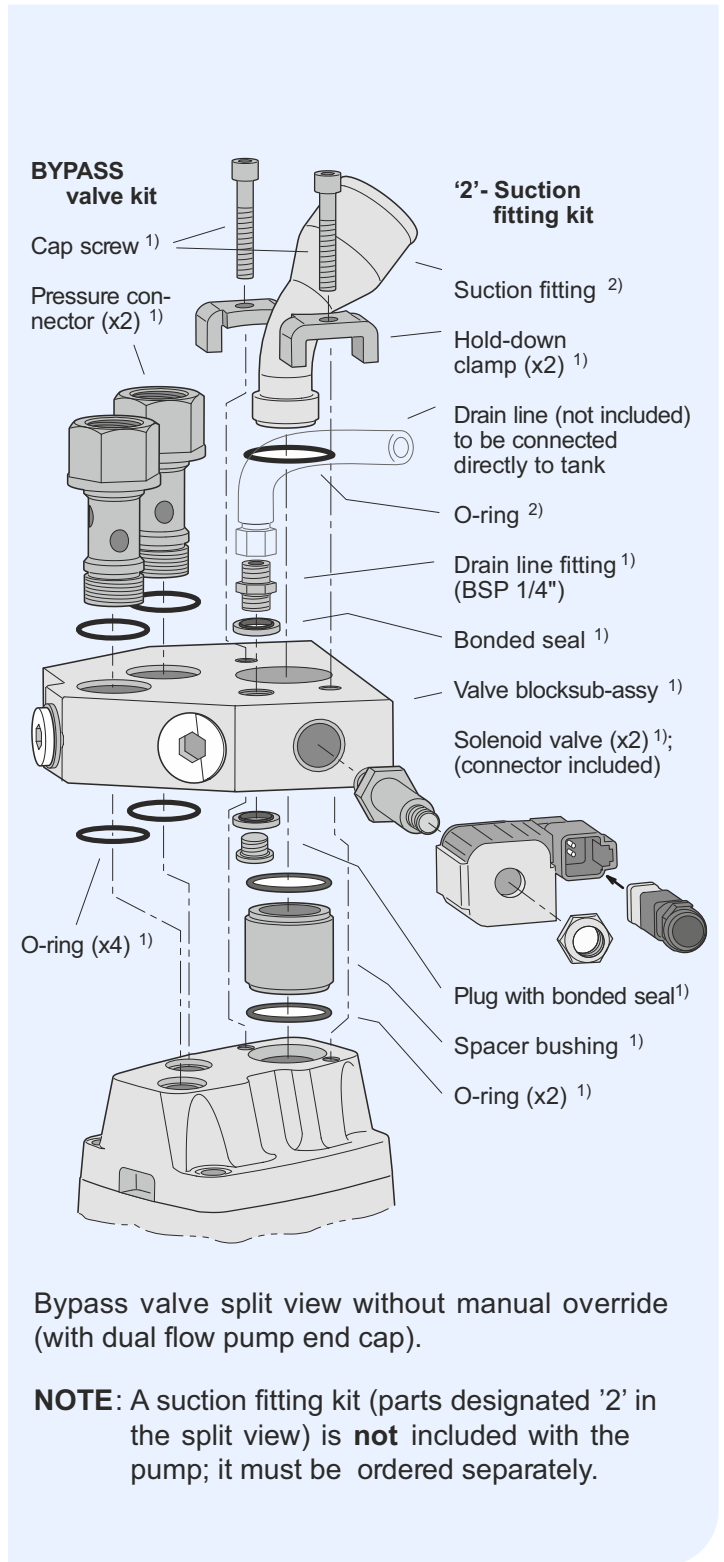

Bypass valve circuit schematic (example).

Bypass valve (Dual Flow Pump)

Without manual override

Bypass valve, type	Dual Flow Pump
Max pressure, continuous	350 bar
intermittent	400 bar
Solenoid voltage (option)	24 VDC, (12 VDC)
Power requirement	14 W (each solenoid)
Operating mode	Activated solenoid: Check valve closed

Bypass valve ¹⁾	Voltage	Ordering number	Dual Flow	Torque ³⁾
ByPass	24 VDC	2400 565	46/46, 53/53, 68/68, 70/70, 76/76.	50 Nm
	12 VDC	1200 565		

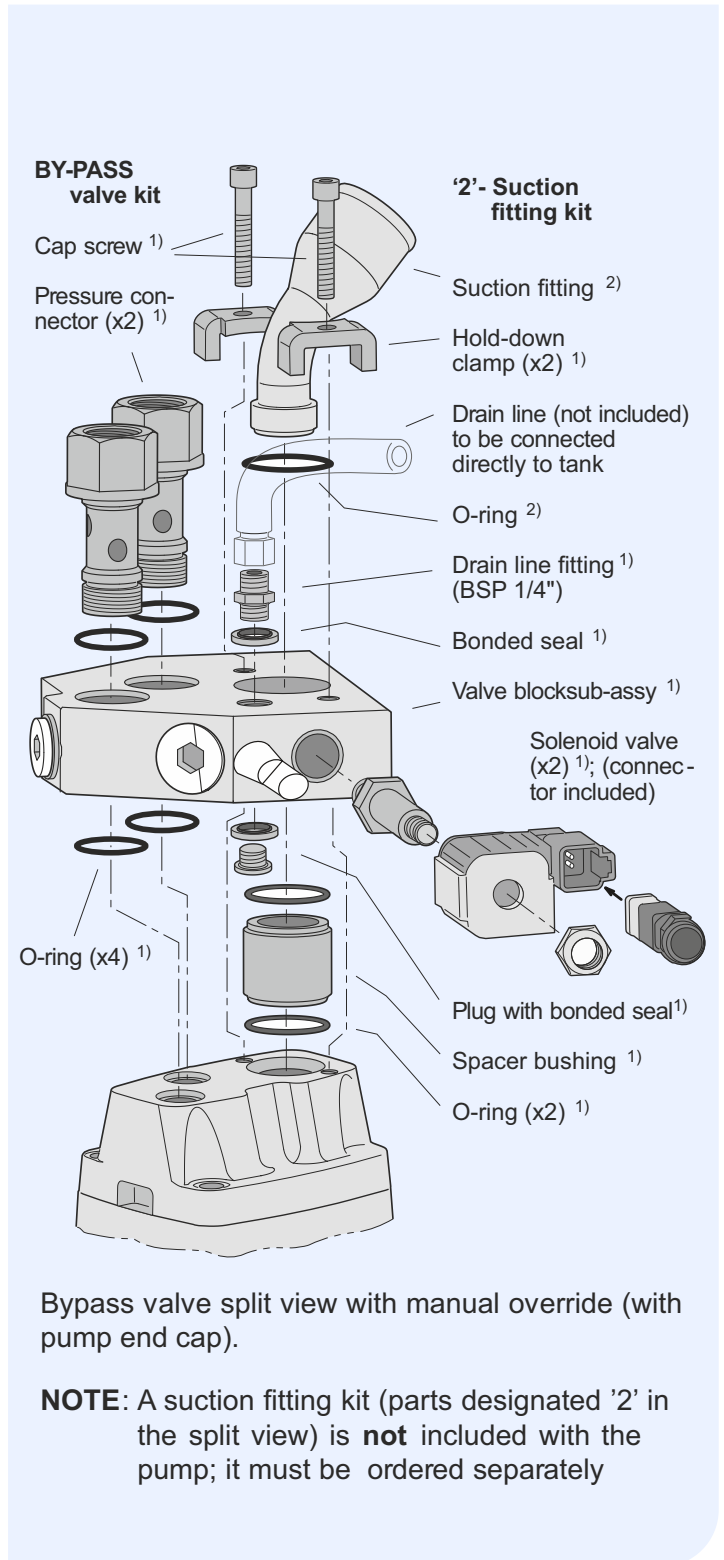
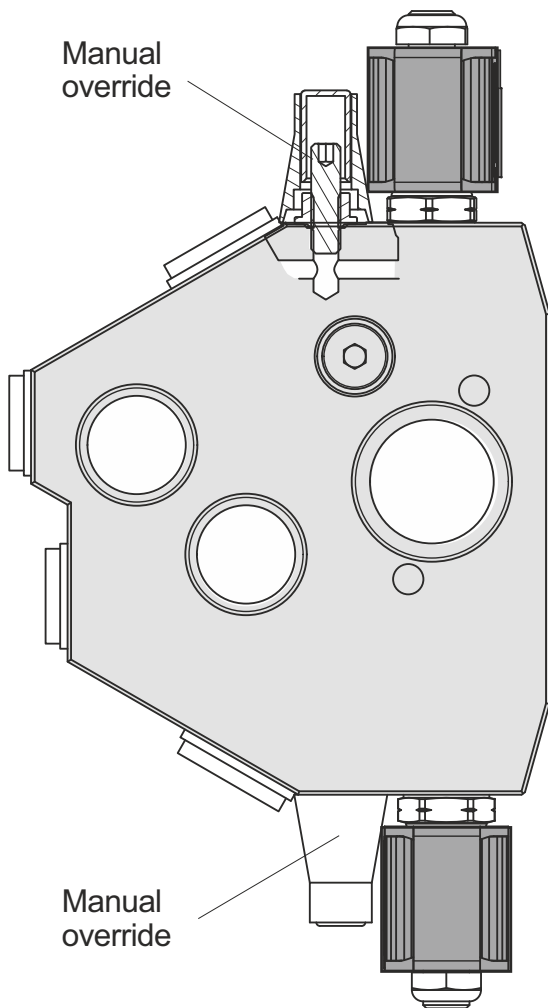

Complete Product Range

Bent Axis Piston Motors

- A9MD** (DIN) Bent Axis Motors
- A9MO** (ISO) Bent Axis Motors
- A9MS** (SAE) Bent Axis Motors
- A9ML** (SAE2) Bent Axis Motors
- A9MF** (Fixed Plugin) Bent Axis Motors
- A10M** (HYBRID) Bent Axis Motors
- A7GM** Hydraulic Gear Motors
- A7GMT** Tandem Hydraulic Gear Motors

Bent Axis Piston Pumps

- A8PA** (Aluminum) Bent Axis Pumps
- A8PD** (DIN) Bent Axis Pumps
- A8PO** (ISO) Bent Axis Pumps
- A8PS** (SAE) Bent Axis Pumps
- A8PF** (Fixed Plugin) Bent Axis Pumps
- A10** (HYBRID) Bent Axis Pumps
- A11** (ISO2) Bent Axis Pumps
- A11** (SAE2) Bent Axis Pumps

Variable Displacement Pumps

- A12V** Variable Displacement Piston Pumps

Dual Flow Piston Pumps

- A8PL** (DIN) Dual Flow Pumps

Axial Piston & Gear Pumps

- A4PP** Axial Hydraulic Piston Pumps
- A6HP** High Pressure Piston Pumps
- A7GP** Hydraulic Gear Pumps
- A7GPT** Tandem Hydraulic Gear Pumps

Valve (ByPass) (Flushing) (Cavitation)

- Circulation Valve
- ByPass Valve
- Anti-Cavitation Valve
- Flushing Valve
- LS Valve
- AntiShock Valve
- Speed Sensor

Hydraulic Spare Parts

- Suction Fittings
- Couplers
- Adapters
- Flanges
- Power Take Off
- Monoblock Valve
- Section Valve

Hydraulic Pumps, Motors

Bent Axis Hydraulic Piston Motors, Bent Axis Hydraulic Piston Pumps, Piston Pumps, Variable Displacement Piston Pumps, Variable Displacement Piston Motors, Axial Piston Pumps, High Pressure Piston Pumps, Gear Pumps, Gear Motors, Hydraulic Valve.

www.goldhydraulics.com

Address;

HYDROGOLD HİDROLİK PNM. MAK. SAN. TİC. LTD. ŞTİ.

Address; (Fabrika, İmalat)

Fevzicakmak Mah. Sıla Cad. Kobisan 3 San. Sit.

No: 73 / C Karatay – Konya, PO Code; 42050, Türkiye

Address; (Montaj, Sevkiyat)

Fevzicakmak Mah. Sıla Cad. Kobisan 3 San. Sit.

No: 71 / AD Karatay – Konya, PO Code; 42050, Türkiye

Phone; +90 551 148 26 88

mail@goldhydraulics.com