

## A9MF (Fixed Plugin) Bent Axis Piston Motor

**Fixed Plugin**, High Pressure Hydraulic Bent Axis Piston Motors, High Pressure, 450/500 BAR Working Pressure. High Rotational Speed, High Efficiency, Slim Design, Cast Iron Motor Body, Re-Designed in 2025.

### Designation;

28cc, 32cc, 41cc, 50cc, 56cc,  
63cc, 80cc, 90cc, 108cc, 125cc

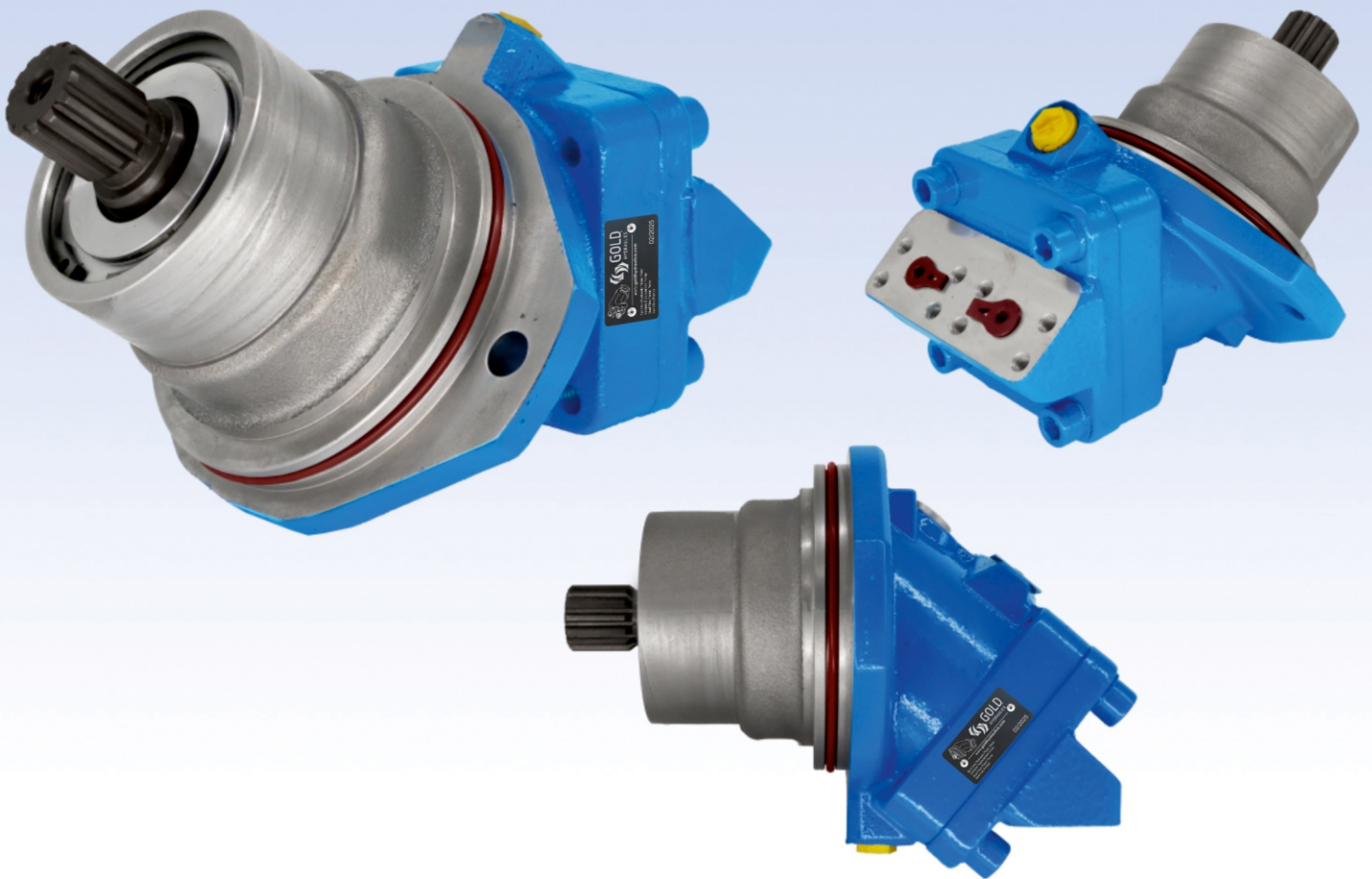

[www.goldhydraulics.com](http://www.goldhydraulics.com)

## Characteristics of the A9MF (Fixed Plugin) Flange Bent Axis Motors

MOTOR MODEL	DISPL. (cc)	CONTINUOUS MAX. SPEED (rpm)	INTERMITTENT MAX. SPEED (rpm)	MAX. FLOW ABSORBED (l/mn)	TORQUE BAR (m.N/bar)	TORQUE AT 350 BAR (m.N)	THEORETICAL MAX. POWER AT 400 BAR (HP / kW)	MAX. ALLOW PRESSURE CONTN./PEAK (bar)	WEIGHT (kg)
28 cc	28.0	6300	6900	158	0.40	139	140.0 / 104.4	400 / 450	11.4
32 cc	32.0	6300	6900	202	0.50	178	180.5 / 134.4	400 / 450	11.5
41 cc	41.0	5600	6200	230	0.65	228	205.2 / 153.1	400 / 450	11.6
50 cc	50,3	5000	5500	252	0.80	280	224.1 / 167.5	400 / 450	18.1
56 cc	56,0	5000	5500	280	0.90	320	244.5 / 187.1	400 / 450	18.1
63 cc	63.0	5000	5500	315	1.00	351	281.6 / 209.1	400 / 450	18.2
80 cc	80,4	4500	5000	362	1.27	447	323.6 / 241.5	400 / 450	26.1
90 cc	90,1	4500	5000	405	1.43	500	361.5 / 269.9	400 / 450	26.2
108 cc	108	4000	4400	435	1.70	598	328.8 / 245.6	400 / 450	33.2
125 cc	125	3400	4400	428	2.00	698	382.6 / 284.6	400 / 450	33.8

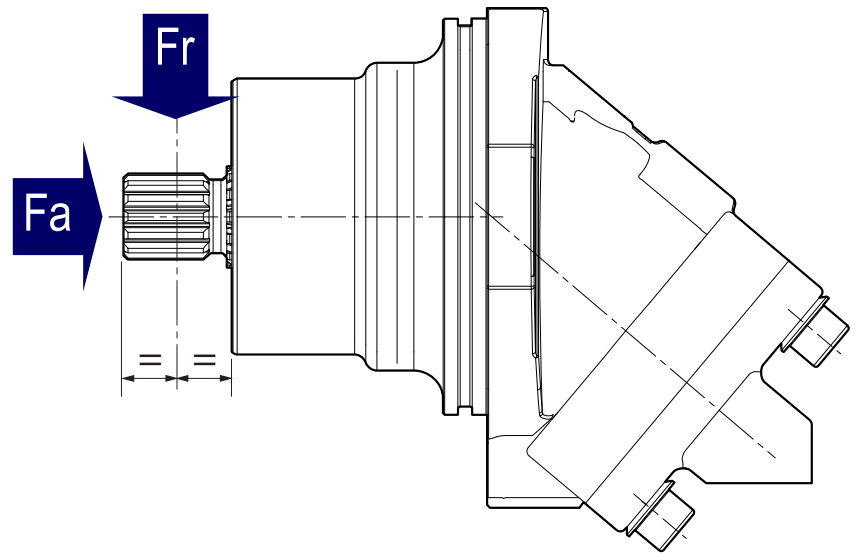

Motor model	28 cc	32 cc	41. 45	50 cc	56, 63cc	80,90,108	125 cc
Fr ( lbf )	1350	1462.5	1462.5	1686	2023	2812	3262
Fr ( N/bar)	6000	6500	6500	7500	9000	12500	14500
Fa ( lbf )	0.42	0.46	0.62	0.62	0.77	1.24	1.33
Fa ( N/bar)	(27)	(30)	(40)	(40)	(50)	(80)	(86)

## Ordering Code; A9MF - Fixed Plugin Bent Axis Motors

Model Code	Displacement	Shaft Type	Flange + Cover Type	Rotation	Sealing
<b>A9MF</b>	<b>28</b>	<b>S14</b>	<b>B2-R45</b>	<b>W</b>	<b>V</b>
<b>A9MF</b> Bent Axis Hydraulic Motor Fixed Plugin	28	<b>S14</b> Splined Shaft W30x2x30x14x9g	<b>B2</b> 2 Bolt ISO 3019-2	<b>W</b> Direction of Rotation Reversible Independet	<b>V</b> Viton High Pressure Seal
	32				
	41				
	50				
	56				
	63	<b>S16</b> Splined Shaft W35x2x30x16x9g	<b>R45</b> SAE Flange Ports Bottom		<b>N</b> Nitrile Seal 5/10 Bar
	80				
	90				
	108	<b>S18</b> Splined Shaft W40x2x30x18x9g			
125					
		<b>S21</b> Splined Shaft W45x2x30x21x9g			

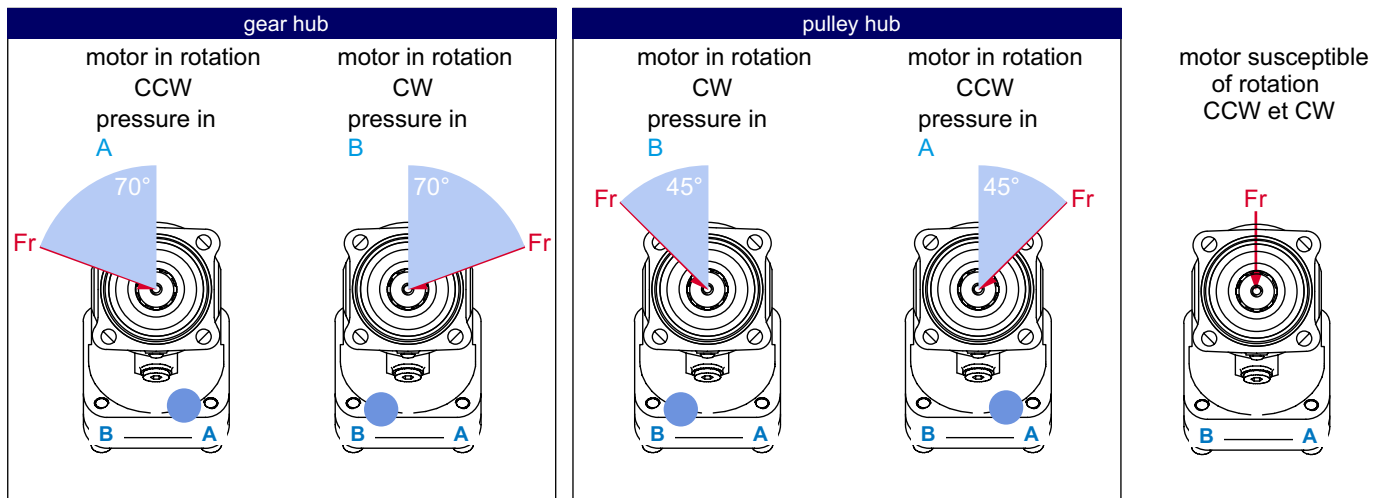



# A9MF - 32 cc (Fixed Plugin) - 2 Bolt

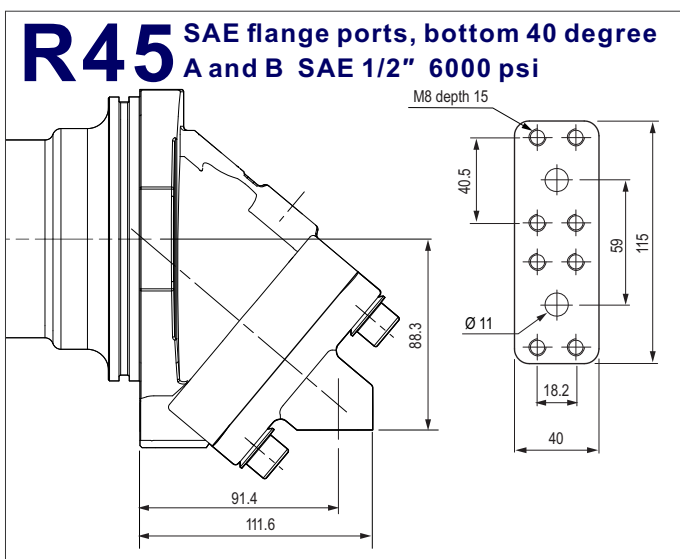
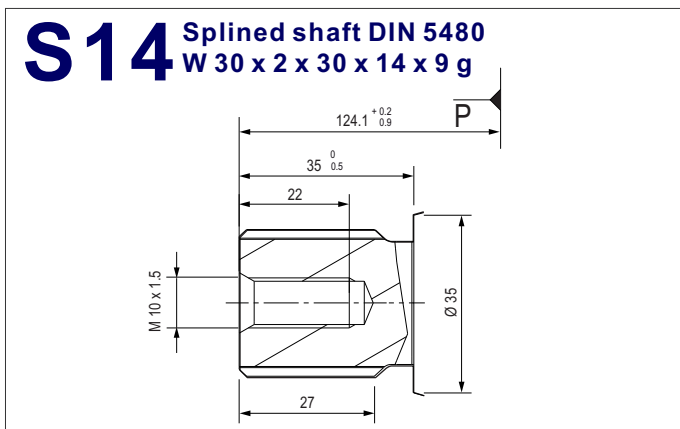
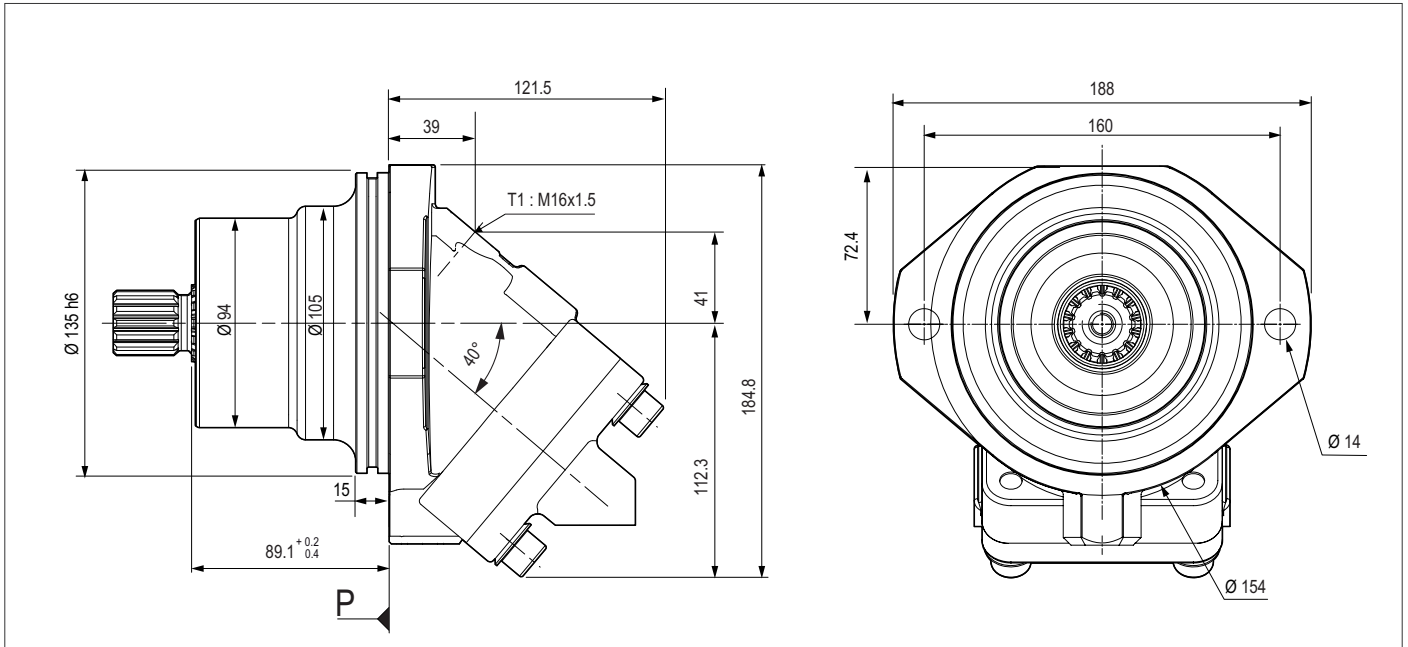



# A9MF - 50 cc (Fixed Plugin) - 2 Bolt

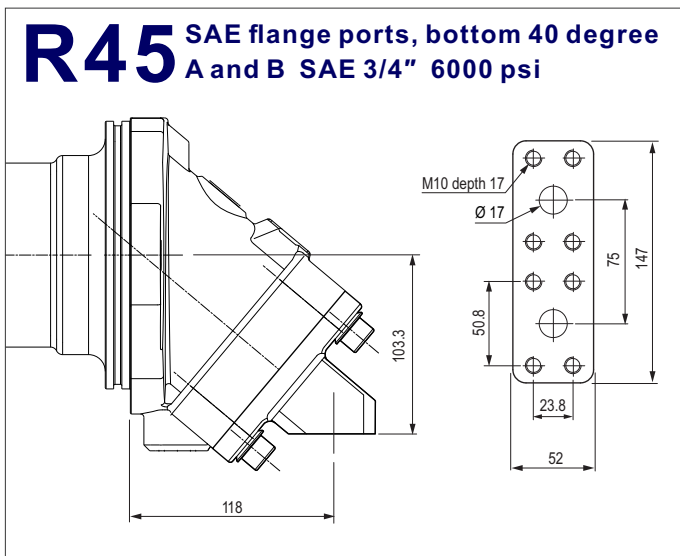
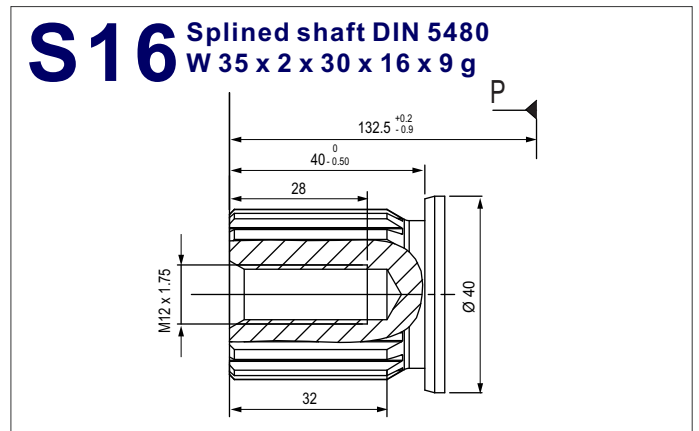
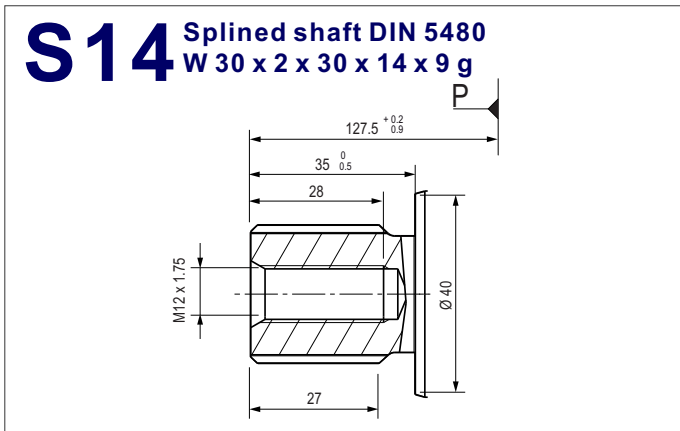
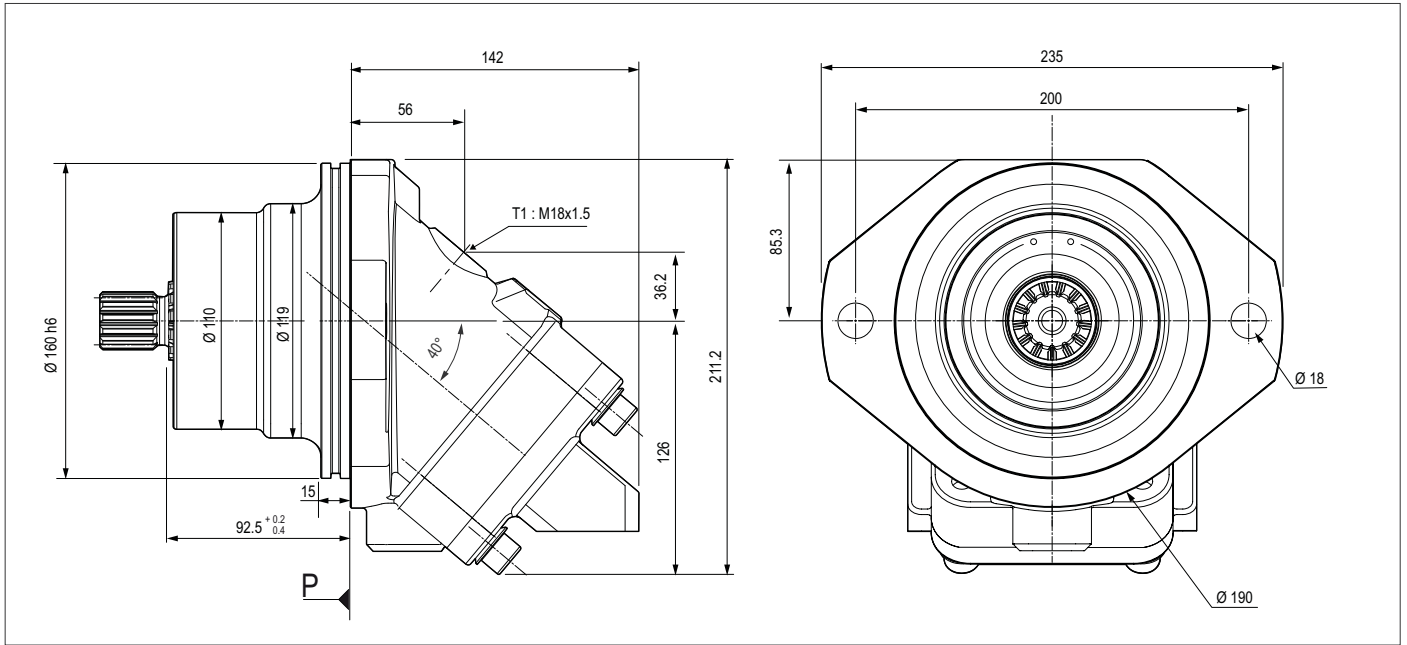

# A9MF - 56 cc (Fixed Plugin) - 2 Bolt

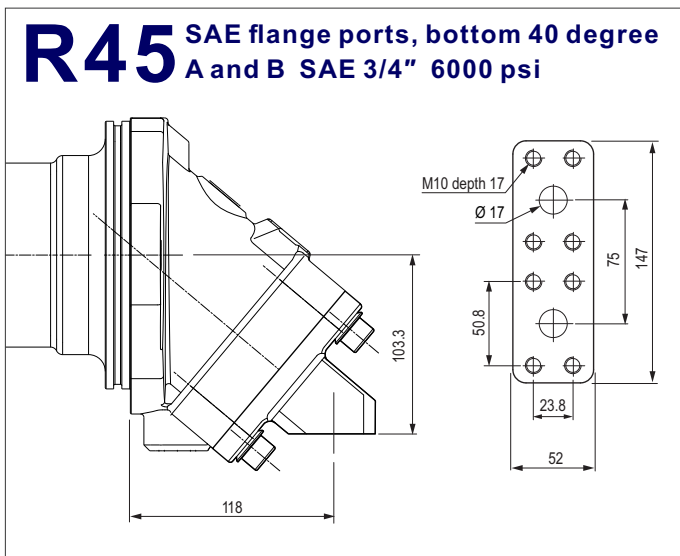
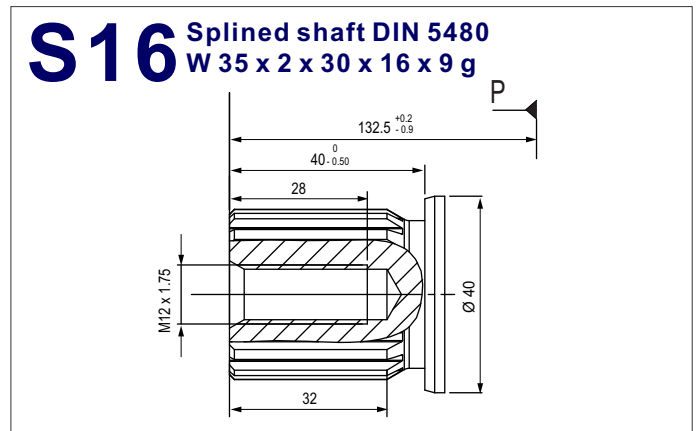
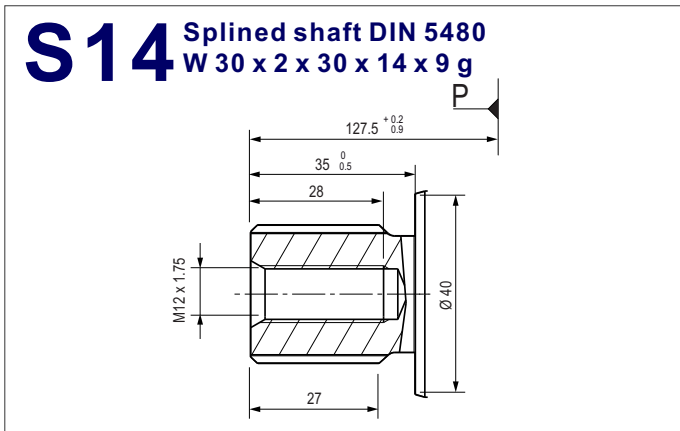
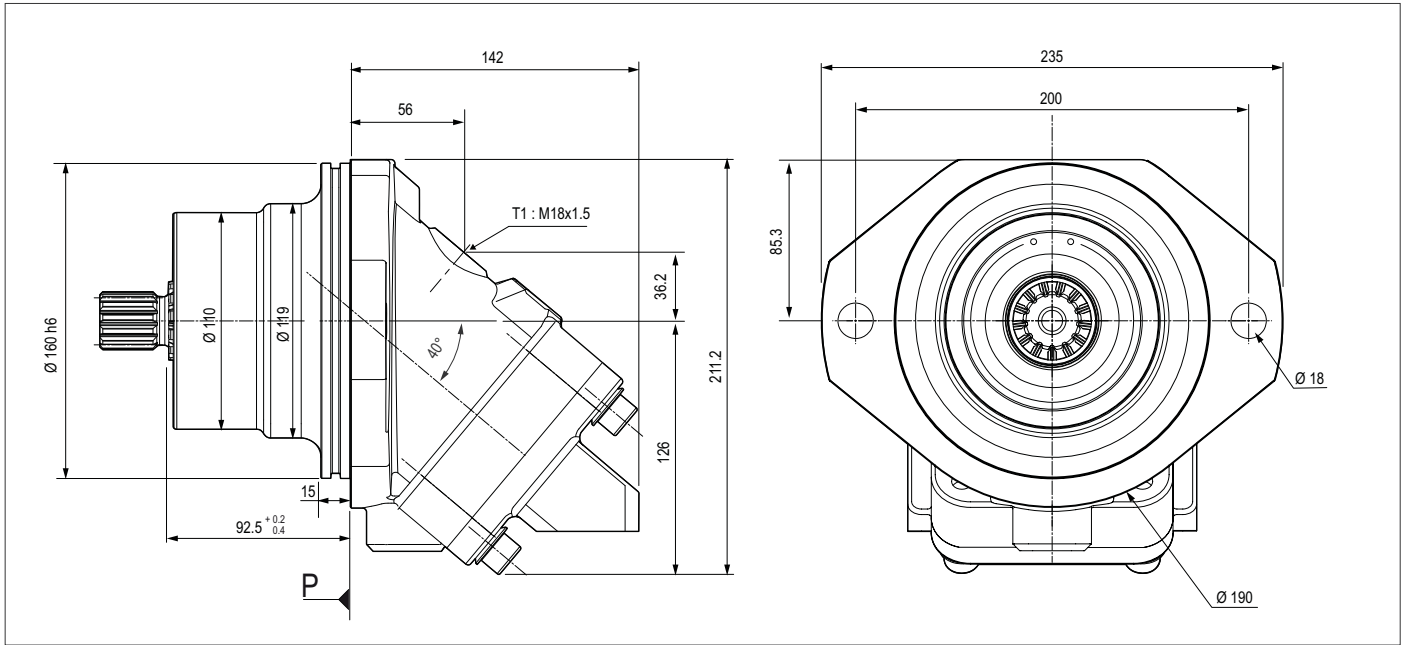



# A9MF - 63 cc (Fixed Plugin) - 2 Bolt

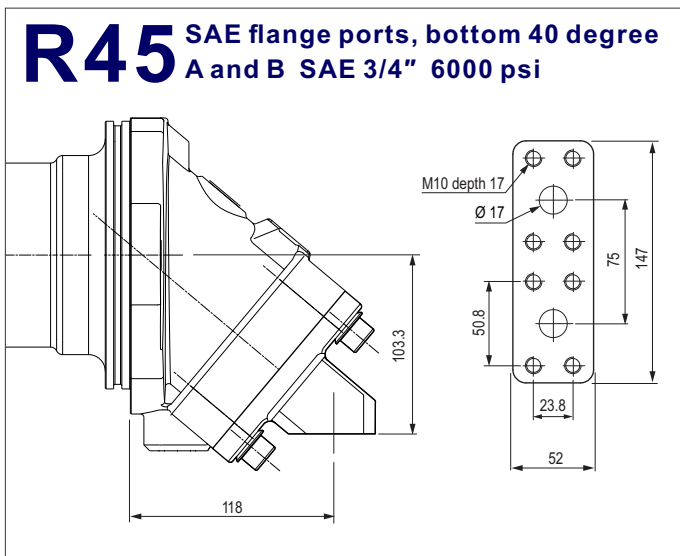
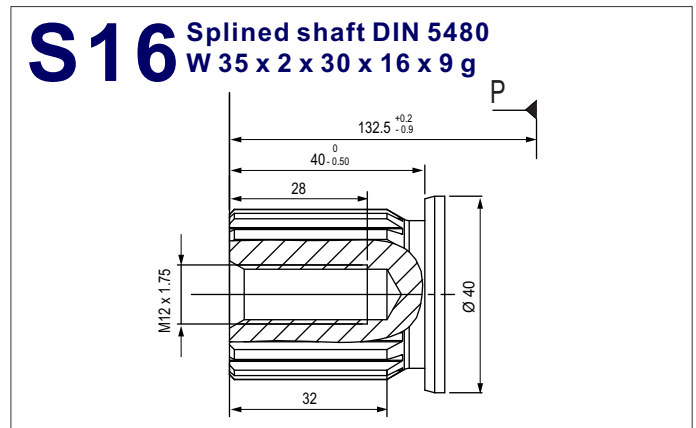
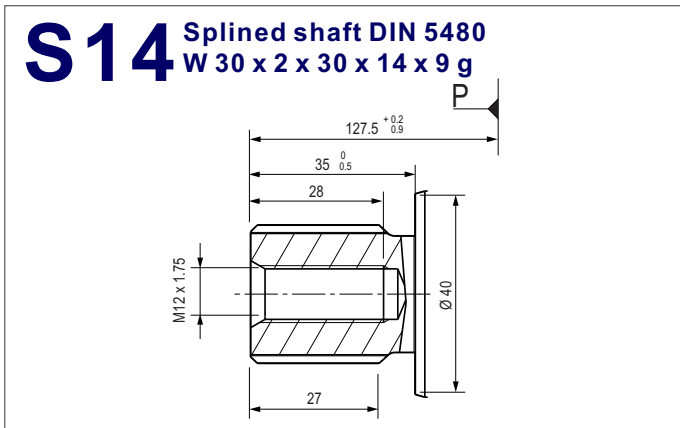
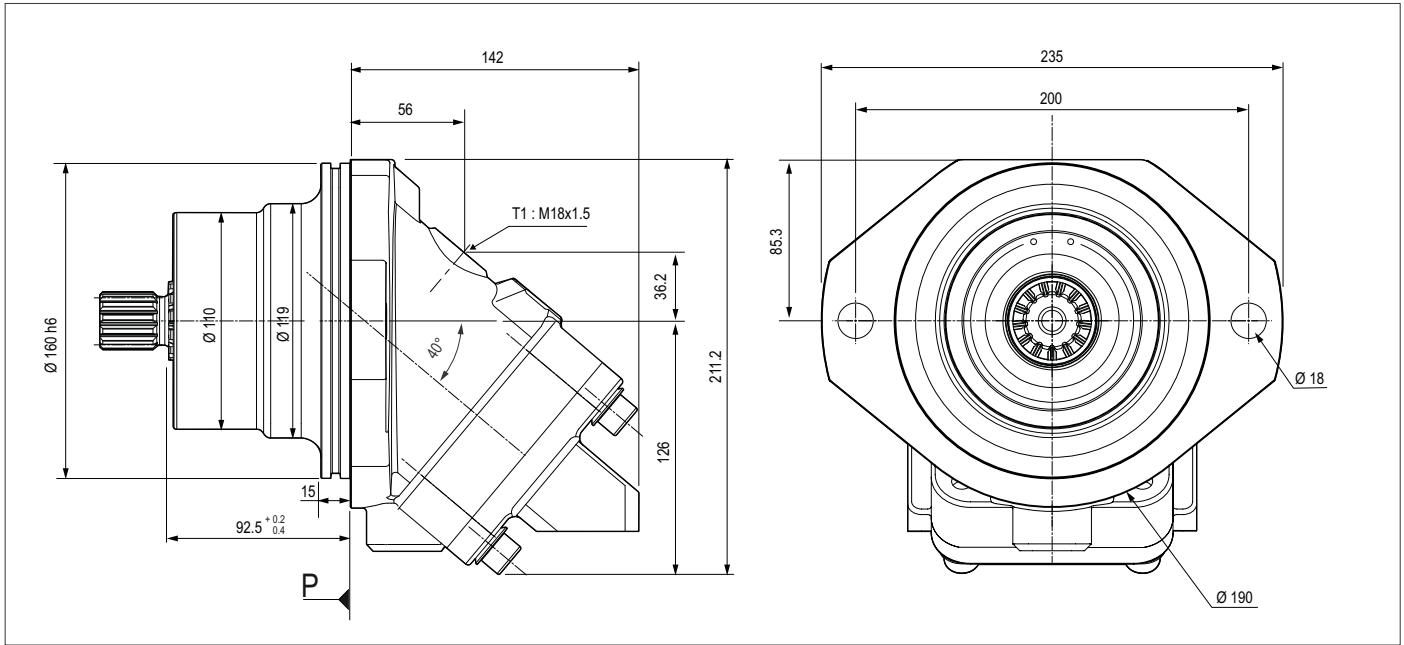

# A9MF - 80 cc (Fixed Plugin) - 2 Bolt

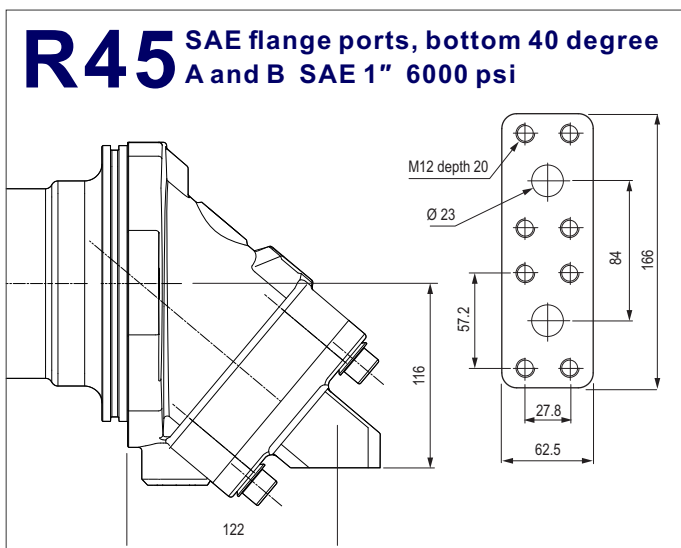
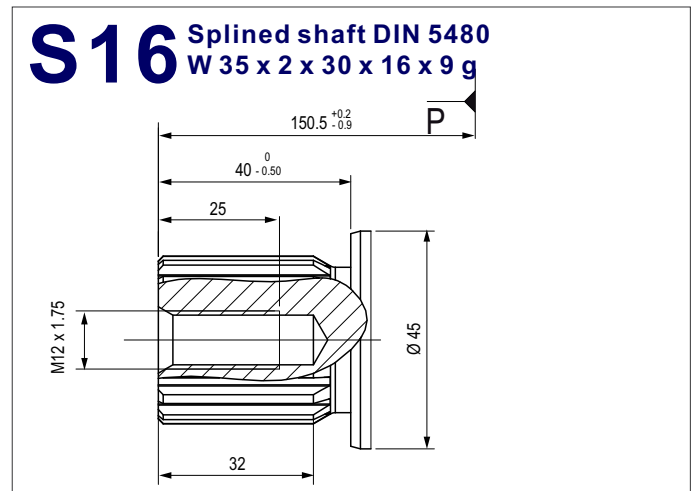
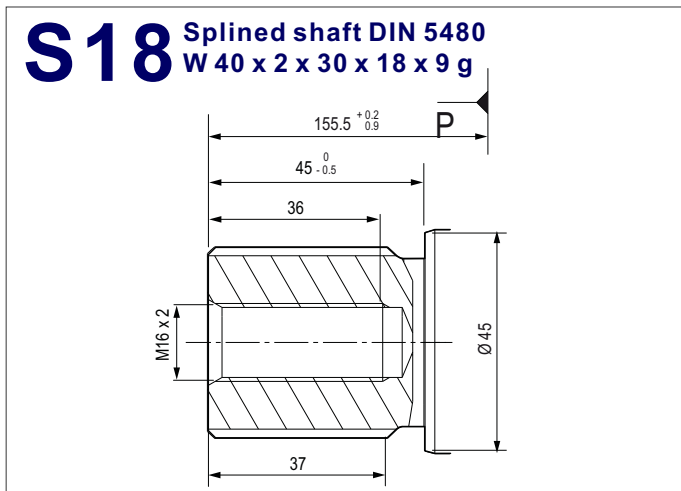
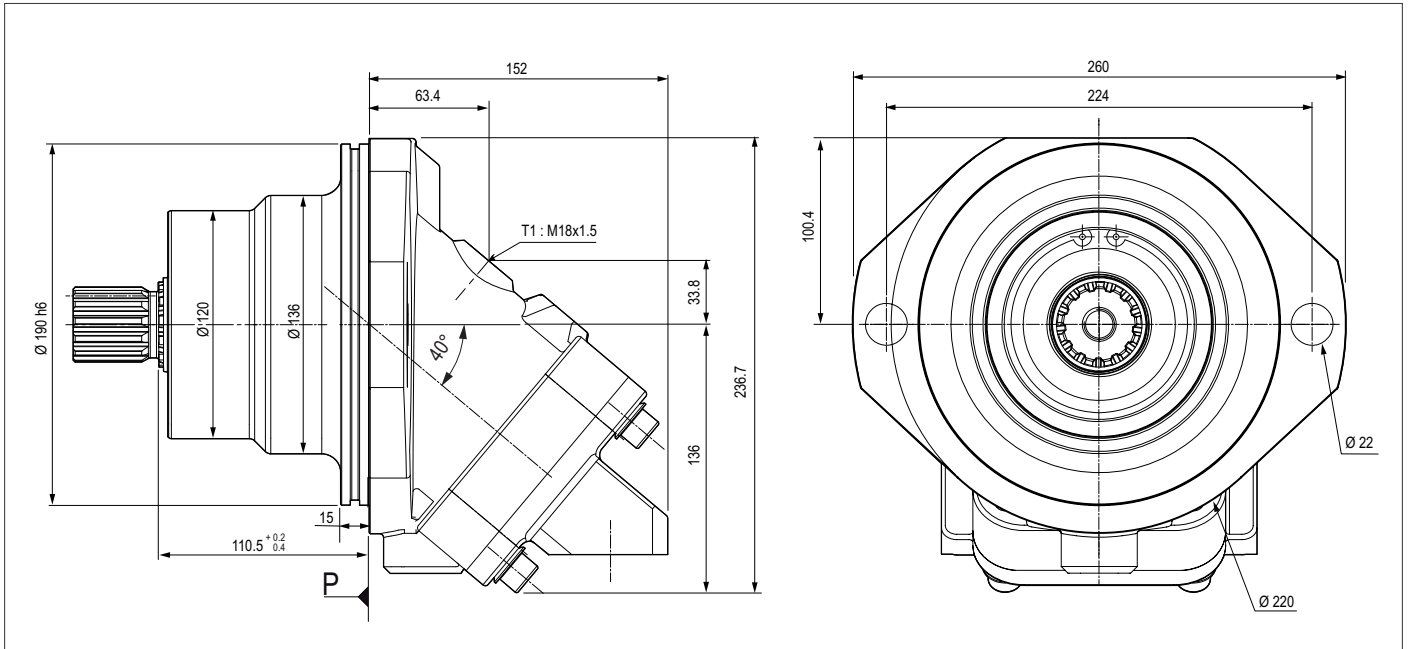

# A9MF - 90 cc (Fixed Plugin) - 2 Bolt

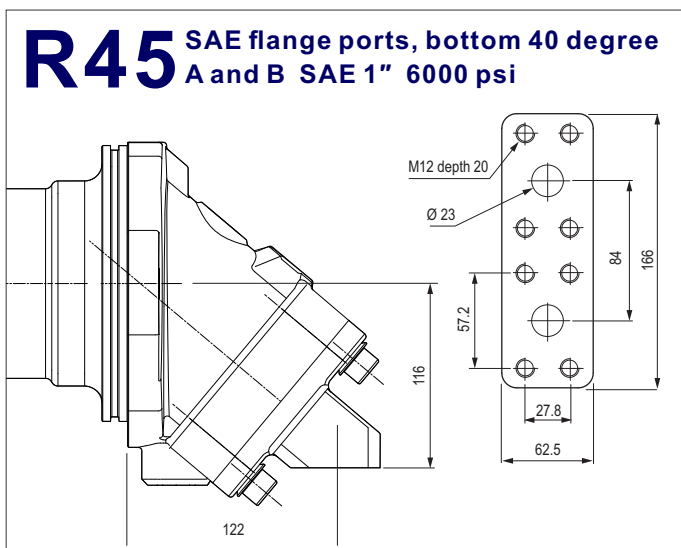
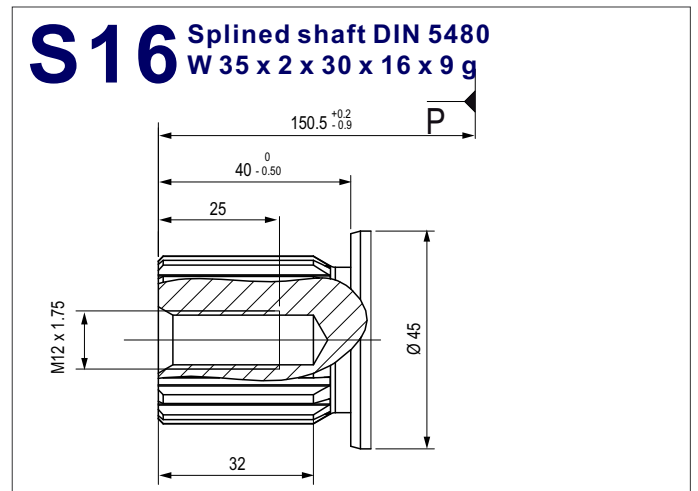
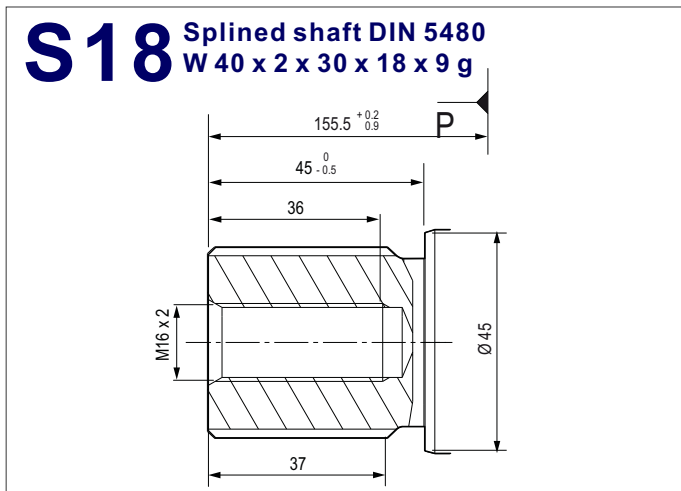
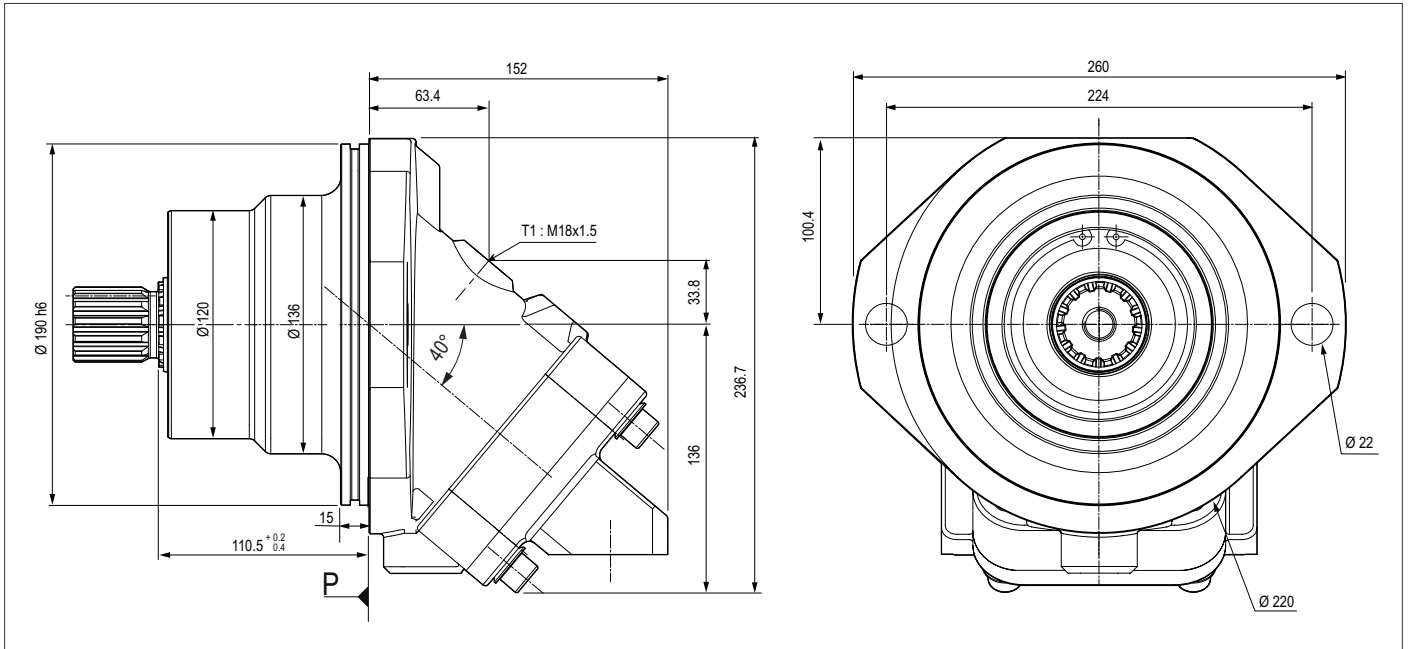



# A9MF - 125 cc (Fixed Plugin) - 2 Bolt

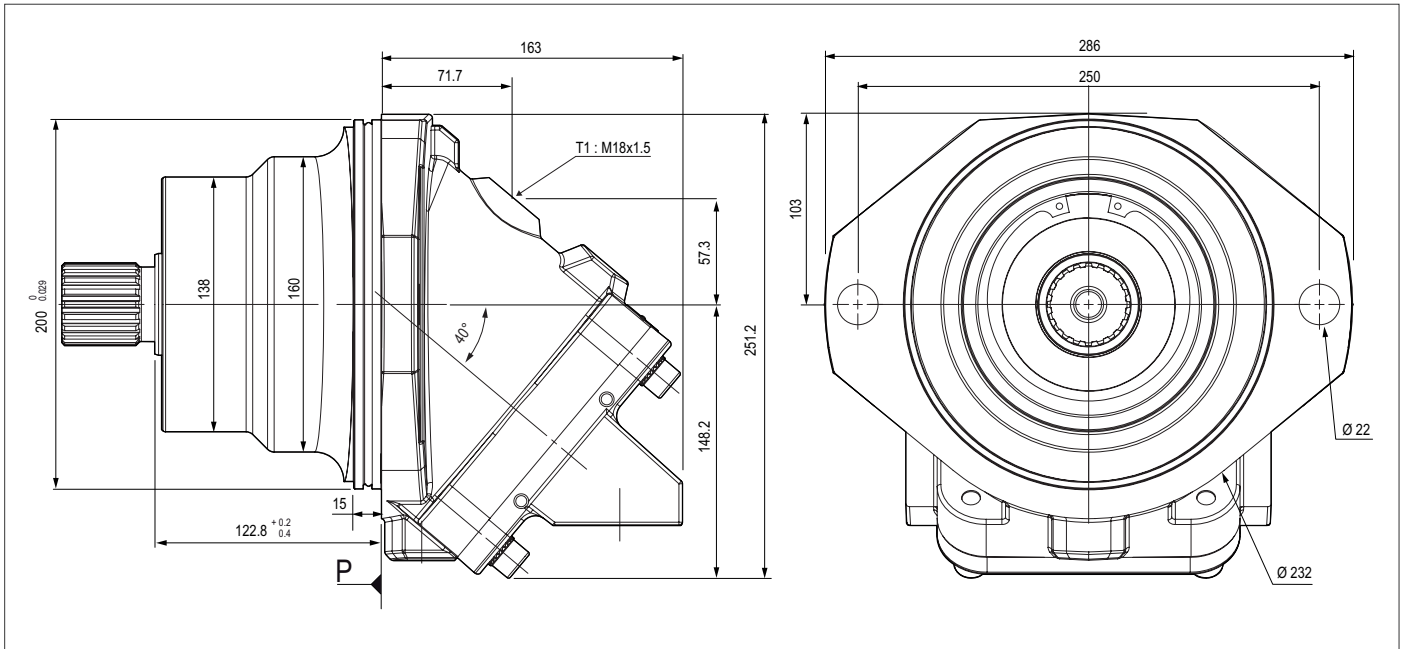

## S21 Splined shaft DIN 5480 W 45 x 2 x 30 x 21 x 9 g

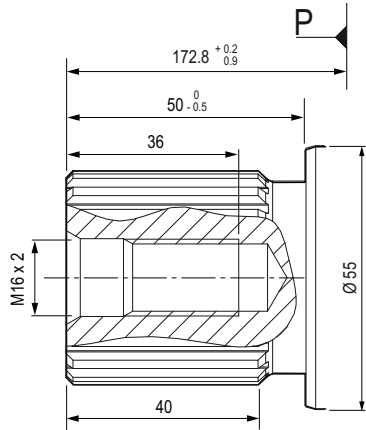

## S18 Splined shaft DIN 5480 W 40 x 2 x 30 x 18 x 9 g

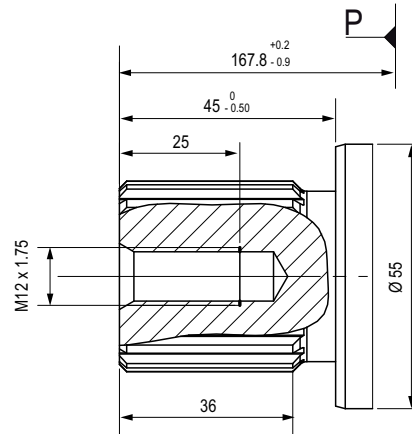

## R45 SAE flange ports, bottom 40 degree A and B SAE 1" 1/4 6000 psi

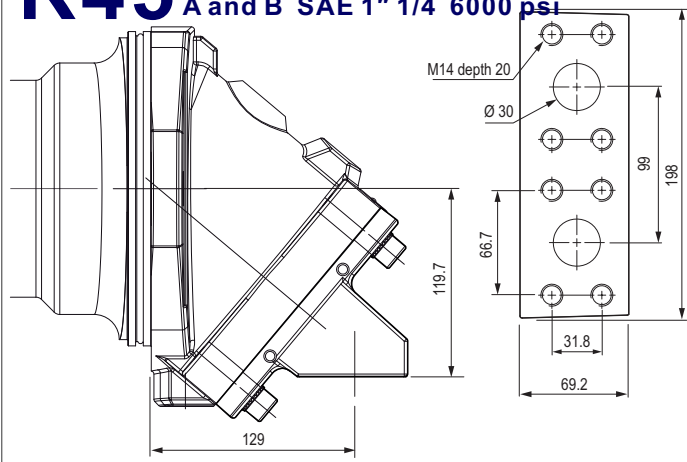

## Direction of Rotation; Reversible

The motors rotate clockwise or counter-clockwise depending on the direction of hydraulic flow entering the motor.

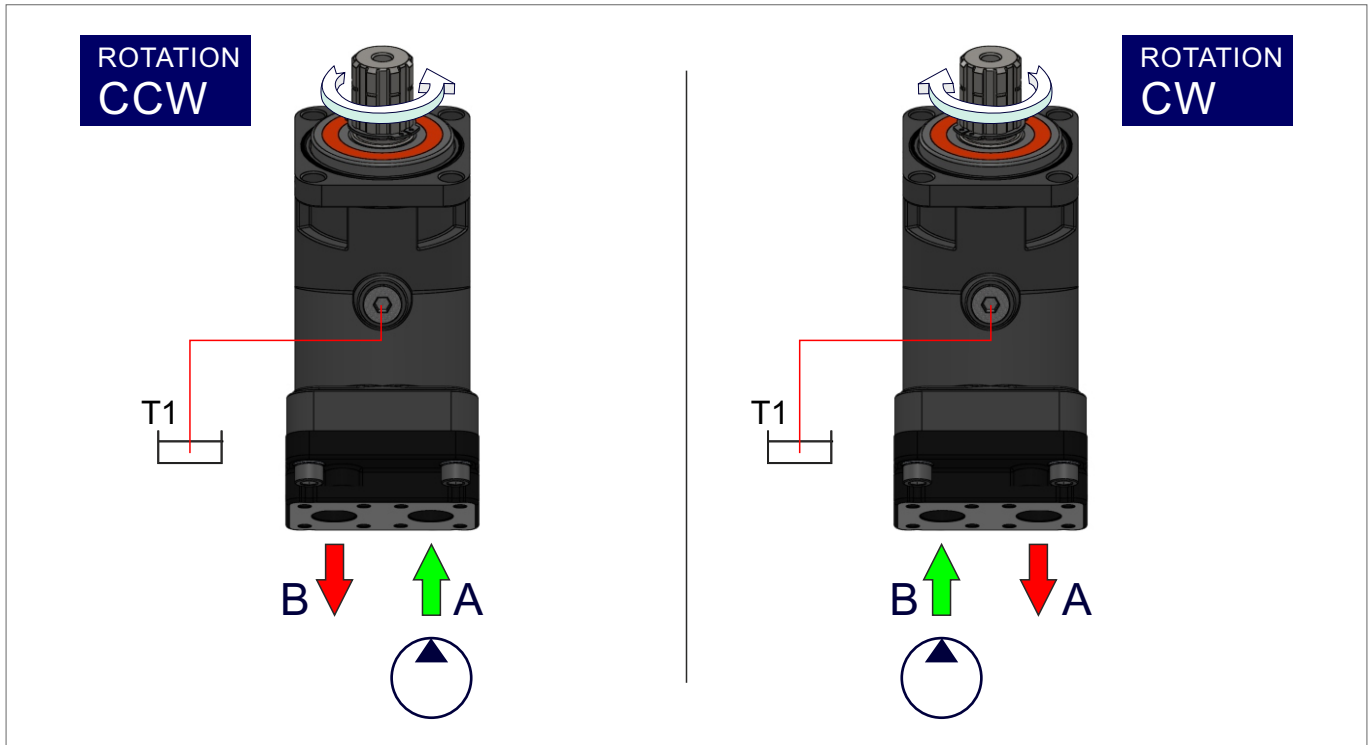

Formulas			
<b>Pump Output Flow</b>	GPM	$GPM = (\text{Speed (rpm)} \times \text{disp. (cu. in.)}) / 231$	$GPM = (n \times d) / 231$
<b>Pump Input Horsepower</b>	HP	$HP = GPM \times \text{Pressure (psi)} / 1714 \times \text{Efficiency}$	$HP = (Q \times P) / 1714 \times E$
<b>Pump Efficiency</b>	E	Overall Efficiency = Output HP / Input HP	$E_{\text{Overall}} = \text{HPOut} / \text{HPIn} \times 100$
		Overall Efficiency = Volumetric Eff. $\times$ Mechanical Eff.	$E_{\text{Overall}} = \text{EffVol.} \times \text{EffMech.}$
<b>Pump Volumetric Efficiency</b>	E	Volumetric Efficiency = Actual Flow Rate Output (GPM) / Theoretical Flow Rate Output (GPM) $\times$ 100	$\text{EffVol.} = \text{QAct.} / \text{QTheo.} \times 100$
<b>Pump Mechanical Efficiency</b>	E	Mechanical Efficiency = Theoretical Torque to Drive / Actual Torque to Drive $\times$ 100	$\text{EffMech} = \text{TTheo.} / \text{TAct.} \times 100$
<b>Pump Displacement</b>	CIPR	$\text{Dsplcmnt (In.}^3 \text{ / rev.)} = \text{Flow Rate (GPM)} \times 231 / \text{Pump RPM}$	$\text{CIPR} = \text{GPM} \times 231 / \text{RPM}$
<b>Pump Torque</b>	T	Torque = Horsepower $\times$ 63025 / RPM	$T = 63025 \times \text{HP} / \text{RPM}$
		Torque = Pressure (PSIG) $\times$ Pump Displacement (CIPR) / $2\pi$	$T = P \times \text{CIPR} / 6.28$

- Horsepower for driving a pump** : For every 1 hp of drive, the equivalent of 1 gpm @ 1500 psi can be produced.
- Horsepower for idling a pump** : To idle a pump when it is unloaded will require about 5% of it's full rated power
- Wattage for heating hydraulic oil** : Each watt will raise the temperature of 1 gallon of oil by 1° F. per hour.
- Flow velocity in hydraulic lines** : Pump suction lines 2 to 4 feet per second, pressure lines up to 500 psi - 10 to 15 ft./sec., pressure lines 500 to 3000 psi - 15 / 20 ft./sec.; all oil lines in air-over-oil systems; 4 ft./sec.

## Installation & Assemble Informations for Bent Axis Motors

### POSITION

Fixed Flange Bent Axis Motors can be operate any position.

### DIRECTION OF ROTATION

Fixed Flange Bent Axis Motors can be operate in both directions of rotation.

Before of Installation operation, the motor must be filled with hydraulic fluid and air bled.

### INSTALLATION POSITION

See following examples.

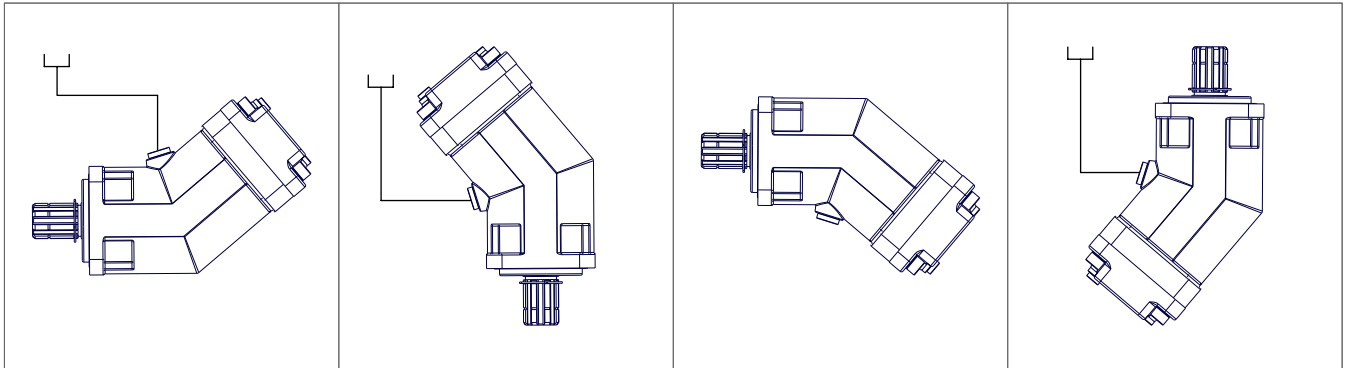

### HYDRAULIC FLUID

Recommended ;

Generally : between 15 and 200 cSt.

Maximum : between 5 and 1600 cSt.

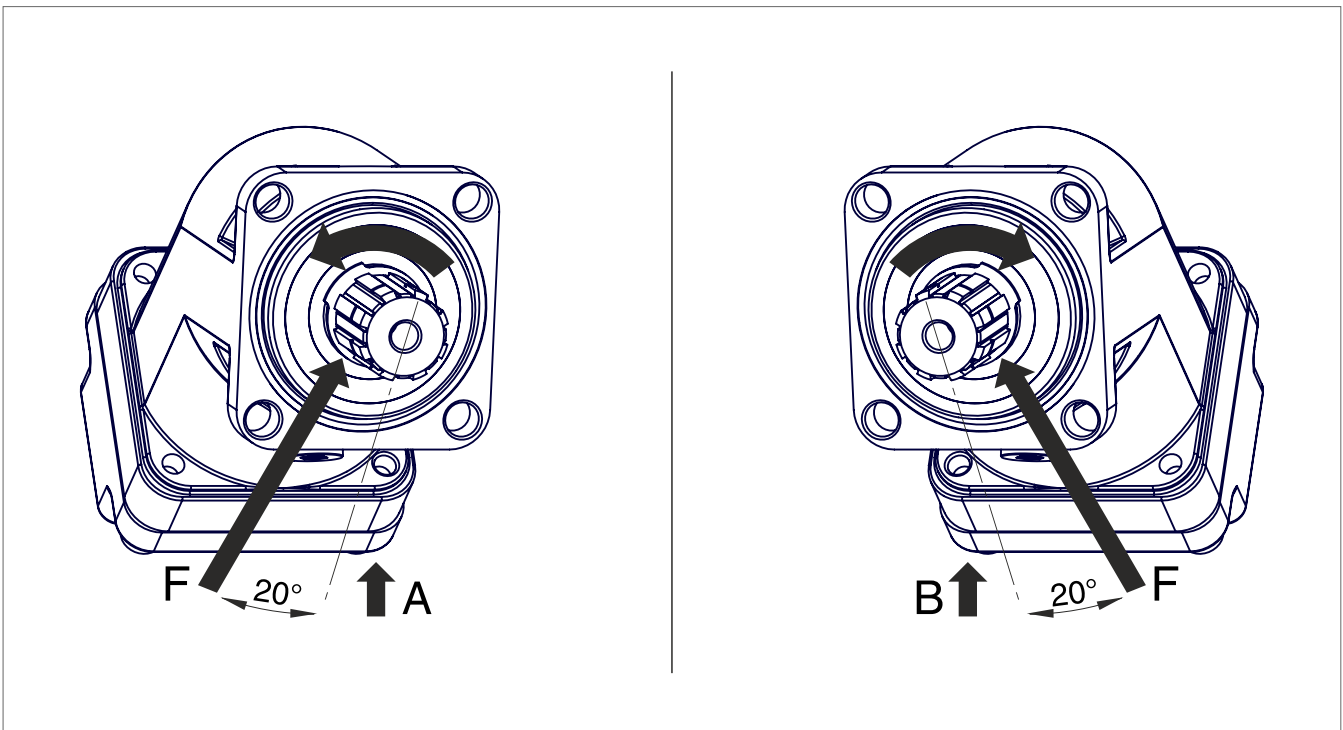

### FOR USE;

Available via e-mail on request or each motor is supplied via Starting datasheet.

## Formulas, Calculations, Installation Guide

### Quick Calculation

#### Flow rate

$$Q = \frac{V_s \cdot n}{1000 \eta_v} \text{ (lpm)}$$

#### Torque

$$M = \frac{V_s \cdot \Delta p \cdot \eta_{mh}}{63} \text{ (Nm)}$$

#### Power

$$P = \frac{2\pi \cdot M \cdot n}{60000} = \frac{M \cdot n}{9549} = \frac{Q \cdot \Delta p \cdot \eta_t}{600} \text{ (kW)}$$

#### Speed

$$n = \frac{1000 \cdot Q \cdot \eta_v}{V_s} \text{ (rpm)}$$

- $V_s$  = Displacement (ccm/rev.)
- $\Delta p$  = Diff. pressure (bar)
- $n$  = Speed (rpm)
- $Q$  = Flow (lpm)
- $\eta_v$  = Volumetric efficiency
- $\eta_{mh}$  = Mechanical-hydraulic efficiency
- $\eta_t$  = Total efficiency ( $\eta_t = \eta_v \times \eta_{mh}$ )

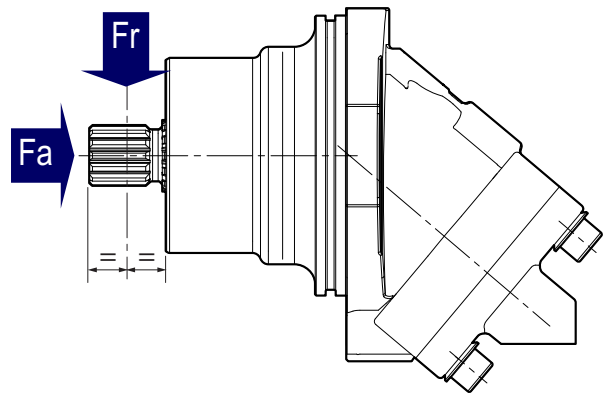

Motor model	28 cc	32 cc	41.45	50 cc	56, 63cc	80,90,108	125 cc
<b>Fr (lbf)</b>	1350	1462.5	1462.5	1686	2023	2812	3262
<b>Fr (N/bar)</b>	6000	6500	6500	7500	9000	12500	14500
<b>Fa (lbf)</b>	0.42	0.46	0.62	0.62	0.77	1.24	1.33
<b>Fa (N/bar)</b>	(27)	(30)	(40)	(40)	(50)	(80)	(86)

### Other Advantages of Flange Bent Axis Motors

- Interchangeable and Compatible with other Bent Axis Motors,
- Special Designed Pistons,
- One-Piece Piston with Piston Rings,
- For use in stationary and mobile applications,
- Compact motor design and extra durable parts,
- High Operational Reliability and High Starting Torque
- Extra Warranty with Wide Service



## Complete Product Range

### Bent Axis Piston Motors

- A9MD** (DIN) Bent Axis Motors
- A9MO** (ISO) Bent Axis Motors
- A9MS** (SAE) Bent Axis Motors
- A9ML** (SAE2) Bent Axis Motors
- A9MF** (Fixed Plugin) Bent Axis Motors
- A10M** (HYBRID) Bent Axis Motors
- A7GM** Hydraulic Gear Motors
- A7GMT** Tandem Hydraulic Gear Motors

### Bent Axis Piston Pumps

- A8PA** (Aluminum) Bent Axis Pumps
- A8PD** (DIN) Bent Axis Pumps
- A8PO** (ISO) Bent Axis Pumps
- A8PS** (SAE) Bent Axis Pumps
- A8PF** (Fixed Plugin) Bent Axis Pumps
- A10** (HYBRID) Bent Axis Pumps
- A11** (ISO2) Bent Axis Pumps
- A11** (SAE2) Bent Axis Pumps

### Variable Displacement Pumps

- A12V** Variable Displacement Piston Pumps

### Dual Flow Piston Pumps

- A8PL** (DIN) Dual Flow Pumps

### Axial Piston & Gear Pumps

- A4PP** Axial Hydraulic Piston Pumps
- A6HP** High Pressure Piston Pumps
- A7GP** Hydraulic Gear Pumps
- A7GPT** Tandem Hydraulic Gear Pumps

### Valve (ByPass) (Flushing) (Cavitation)

- Circulation Valve
- ByPass Valve
- Anti-Cavitation Valve
- Flushing Valve
- LS Valve
- AntiShock Valve
- Speed Sensor

### Hydraulic Spare Parts

- Suction Fittings
- Couplers
- Adapters
- Flanges
- Power Take Off
- Monoblock Valve
- Section Valve

## Hydraulic Pumps, Motors

Bent Axis Hydraulic Piston Motors, Bent Axis Hydraulic Piston Pumps, Piston Pumps, Variable Displacement Piston Pumps, Variable Displacement Piston Motors, Axial Piston Pumps, High Pressure Piston Pumps, Gear Pumps, Gear Motors, Hydraulic Valve.

[www.goldhydraulics.com](http://www.goldhydraulics.com)

### Address;

**HYDROGOLD HİDROLİK PNM. MAK. SAN. TİC. LTD. ŞTİ.**

**Address; (Fabrika, İmalat)**

Fevzicakmak Mah. Sıla Cad. Kobisan 3 San. Sit.

No: 73 / C Karatay – Konya, PO Code; 42050, Türkiye

**Address; (Montaj, Sevkiyat)**

Fevzicakmak Mah. Sıla Cad. Kobisan 3 San. Sit.

No: 71 / AD Karatay – Konya, PO Code; 42050, Türkiye

**Phone; +90 551 148 26 88**

[mail@goldhydraulics.com](mailto:mail@goldhydraulics.com)